

Pressure & Temperature Instrumentation Catalogue



A Trusted Supplier for all Industries.

Products to Trust

Quality and Service

Unified Valve Group Ltd. prides itself as innovators in the industry with Western Gauge & Instruments (WGI) full line up of products. Based on a just-in-time supply chain and distribution model, WGI can meet the changing demands and needs of the marketplace through knowledgeable experts and same-day shipping. The result is an intelligent and customized application fit to solve our customers most complex business requirements.



The WGI “Cactus” logo is the trademark of excellence defining all WGI products to strict standards of quality workmanship and reliability. All WGI products are manufactured in an ISO 9001 Certified facility and have appropriate Canadian Registration Numbers (CRN) meaning that our products have been accepted and registered in each associated Province and/or Territory across Canada.

Stocked Inventory

- Pressure Gauges
- Needle Valves
- Ball Valves
- Manifold Valves
- Thermowells
- Temperature Indicators
- Regulators
- Support Accessories

Calibration Services

WGI is a leading provider of calibration services in Calgary and Edmonton. Through the use of Cardinal and Nominal Point Calibration techniques, we can test and calibrate your devices through trained professionals in an accurate lab and stable environment. This will ensure your devices provide accurate readings and results.

Repairs and Calibration Services

- Repairs include all makes and models of direct drive and standard gauges.
- All calibrations are traceable to the National Institute of Standards and Technology (NIST).
- Deadweight Certificates of Calibration are available upon request.
- Fill options include silicone, specialty fluids or high temperature products as required.
- Installation of stainless steel or aluminum tags.
- Mounting of various instruments to your diaphragm or chemical seals.

Custom Dial Faces

Custom dial faces are available in many different scales including PSI, kPa, kg/cm², cmH₂O, ftH₂O, inH₂O, inHg, oz/in², bar, mbar, MPa and many more.

For more information on Western Gauge & Instruments contact your local Unified branch.

CALGARY 403.215.7800 | EDMONTON 780.469.0090 | BROOKS 403.362.4272 | RED DEER 403.340.3922
GRANDE PRAIRIE 780.539.7800 | BONNYVILLE 780.826.2604 | FORT ST. JOHN 250.787.0080

Selecting a Pressure Gauge

Pressure Gauge Operating Principle

Most standard dial type pressure gauges use a bourdon tube-sensing element generally made of a copper alloy (brass) or stainless steel for measuring pressures 15 PSI and above. Bourdon tube gauges are the industry standard when measuring pressure and vacuum. The construction is simple yet rugged and eliminates the need of any additional power source. During operation, the C-shaped or spirally wound bourdon tube flexes when pressure is applied producing a rotational movement, which in turn causes the pointer to indicate the measured pressure. These gauges are generally suitable for all clean and non-clogging liquids and gaseous media. Low pressure gauges typically use an extremely sensitive and highly accurate capsule design for measuring gaseous media from as low as 15 INWC to 240 INWC (10 PSI). On the other hand, digital gauges use an electronic pressure sensor to measure the pressure and then transmit it to a digital display readout.

Gauge Sizing

The gauge size is defined as the diameter of the dial (ANSI) or case (DIN) for both bourdon tube or capsule pressure gauges. The dial is the viewing area of the gauge that displays the pressure scale and needle pointer. Gauges are available in a wide range of sizes from 1 1/2" up to 12". Generally gauges of higher quality incorporate a larger dial or case.

Mounting & Connections

Lower mount (LM), center back mount (CBM) and/or lower back mount (LBM) are available for most gauge types. Most standard gauges have NPT threaded connections. Many gauges can be panel mounted using either a U-clamp bracket or a front flange option. Pressure gauges should be mounted in the upright position whenever possible.

Pressure Range

A gauge range of twice the normal working pressure is generally selected. The maximum operating pressure in all cases should be limited to 75% of the gauge range. Where alternating pressure and pulsation are encountered, working pressure should be limited to 2/3 of the gauge range.

Pressure Fluid Composition

Copper alloy (brass) or stainless steel is the standard wetted parts (materials in contact with the pressure process media) available on most pressure gauges. Since the sensing element of a pressure gauge may be exposed directly to the measured medium, it is important to consider the characteristics of this media. It may be corrosive, solidify at various temperatures, or contain solids that may leave deposits inside the sensing element. Based on these characteristics, a standard bourdon tube gauge is recommended when pressure fluids that will not solidify under normal conditions or leave deposits is present. Otherwise, a seal-gauge or gauge with a chemical seal/gauge protector should be considered.

Gauge Case & Housing

Stainless steel, black ABS and painted steel are standard case materials, a material suitable for every application. Stainless or ABS cases are recommended for outdoor service. While industrial and process gauges come standard with silicone, or a glycerin fill is an option.

Front Ring & Window

The front ring of the gauge holds the viewing window in place and is available in a number of choices including acrylic, stainless steel, brass, steel and thermoplastic. Some rings are a permanent crimp design, while others can be removed providing dial/pointer access for recalibration or repair. Window materials are typically clear acrylic, polycarbonate, flat glass or safety glass.

Temperature & Ambient Conditions

The normal ambient temperature range for most standard dry or silicone filled gauges is -40° F — 140° F and -4° F — 140° F for glycerin filled gauges. The error caused by temperature change is +/- 0.3% per 18° F rise or fall, respectively. This correction represents the temperature of the gauge and not the temperature of the measured medium. Steam and other hot media may raise the safe working limits of the gauge where siphons, cooling towers or chemical diaphragm seals may be required. Moisture and weather effects must also be considered. Thus, liquid filled gauges can mitigate condensation build up while stainless steel, brass or plastic cased gauges are recommended for outdoor use.

Accuracy

Gauges are available with accuracies spanning from +/- 3/2/3% to 0.05% (ASME grade B to grade 4A). Gauges with +/- 3/2/3% of span accuracy offer a +/- 2% of span accuracy over the middle third of the scale and +/- 3% of span on the balance of the scale.

Liquid Filled Option

The liquid fill must be compatible with the gauge application accordingly. Liquid filled gauges help absorb vibration and pressure spikes thus increasing the service life of the gauge. The dampening action of the liquid reduces pointer flutter and lubricates the internal parts dramatically reducing wear in the movement. Silicone is the WGI standard fill fluid and provides the best performance across most applications. Silicone has a low viscosity and works well when extreme temperature fluctuation or icing is expected.

Shock, Vibration & Pulsation

Consider liquid filled gauges to enhance the reliability and integrity of the measuring system when operating for long periods under extreme operating conditions. In addition, optional pressure snubbers will reduce pressure spikes and pulsation, pointer flutter and extend the life of the gauge.

Chemical Diaphragm Seals & Gauge Protection

Diaphragm seals are used to isolate pressure gauges and transmitters from clogging and/or corrosive media. Measurement of higher media temperatures can be obtained by adding a seal. Diaphragm seal systems can extend the life of the pressure instruments and reduce the cost of installation and maintenance. Standard diaphragm seal bodies and diaphragms are made of stainless steel (other materials and options are available).

Burst Pressure Rating

WGI pressure gauges have been designed to withstand 30% over the pressure range without damage to the gauge accuracy. In addition, each bourdon tube has been burst tested to 2.5 times the pressure rating for safety purposes.



Index

WGI Pressure Gauges

Pressure Unit Conversion Table.....	1
Classic Series (Dry)	2 - 3
Elite Brass Series Pressure Gauges (Liquid Filled).....	4 - 5
Elite Stainless Steel Series Gauges (Liquid Filled).....	6 - 8
Elite 450 Process Gauges (NACE)	9
Elite 450 all Stainless Safe Case	10
Diaphragm Gauges (Dry).....	11
Differential Pressure Gauges.....	12
Sprinkler Gauge	13
Agricultural & Refrigeration Ammonia Pressure Gauge.....	14



WGI Pressure Gauge Accessories

Diaphragm / Chemical Seals.....	15
Teflon Tapes.....	16
Rubber Pressure Gauge Guards	16
General Purpose Pressure Snubbers	17
Pressure Limiting Valve (Gauge Minder)	18
Barrel & Pigtail Siphons.....	19



WGI Temperature Gauges

Master-Temp 200/300 Bimetal Thermometers.....	20
Master-Temp 500 Bimetal Thermometers.....	21 - 22
Thermowells.....	23 - 24
9" Industrial Thermometer.....	25
7" Adjustable Angle Thermometer	26
Tridicators (Pressure/Temperature/Altitude).....	27 - 29
Pocket Test Thermometers.....	30
Hot Water Heating Thermometer	31
Magnetic Surface Thermometer.....	32
1441E Digital Min/Max Thermometer	33
Infrared Thermometer	33
Thermocouple & RTD's.....	34



WGI Valves

201 Carbon Steel Ball Valves.....	35
301CSA/CGA Stainless Steel Ball Valves	36
401 Stainless Steel Ball Valves Seal Weld	37
501 Stainless Steel Ball Valves.....	38
601 Series Brass Ball Valves.....	39
701/702 Series Brass CSA Ball Valve NPT/Solder	40
BKH/BK3 Series High Pressure Ball Valves	41
Soft Seat In-Line Check Valves.....	42
Hard Seat Needle Valves - Carbon Steel	43
Hard Seat Needle Valves - Stainless Steel.....	44
Soft Seat Needle Valves - Carbon/Stainless Steel.....	45
Multi Port Valves	46
Block & Bleed Valves.....	47
Miniature Needle Valves - Hard & Soft Seat.....	48 - 50
Packager Needle Valves - Carbon Steel.....	51
Packager Needle Valves - Stainless Steel.....	52
2 Valve Hard Seat Threaded Manifold.....	53
3 Valve Hard Seat Threaded Manifold.....	54
5 Valve Soft Seat Threaded Manifold	55



Regulators

Norriseal-WellMark.....	56 - 57
-------------------------	---------

Level Controls

Norriseal-WellMark.....	58
-------------------------	----

Motor/Burner Control/Operated Dump Valves

Norriseal-WellMark.....	59
-------------------------	----

Ball/Gate/Globe/Check/Plug Valves

FBV.....	60-61
----------	-------



Pressure Unit Conversion Table

To use this Chart:

1. Find the column with the units you want to convert from.
2. Move down that column until you find the "1".
3. Staying in the same row, move horizontally to the column with the units you are converting to.
4. Multiply the number in that box by the amount you are changing from to get the converted value.

PSI	atms	H ₂ O	mmH ₂ O	cm H ₂ O	oz/in ²	kg/cm ²	Hg	mmHg (Torr)	cmHg	mbar	bar	Pa (N/m ²)	kPa	MPa
1	0.0681	27.71	703.8	70.38	16	0.0704	2.036	51.715	5.17	68.95	0.0689	6895	6.895	0.0069
14.7	1	407.2	10,343	1,034.3	235.1	1.033	29.92	760	76	1013	1.013	101,325	101.3	0.1013
0.0361	0.00246	1	25.4	2.54	0.5775	0.00254	0.0795	1.866	0.187	2.488	0.00249	248.8	0.249	0.00025
0.001421	0.000097	0.0394	1	0.1	0.0227	0.001	0.00289	0.0735	0.00735	0.098	0.000098	9.8	0.0098	0.00001
0.01421	0.000967	0.3937	10	1	0.227	0.001	0.0289	0.735	0.0735	0.98	0.00098	98	0.098	0.0001
0.0625	0.00425	1.732	43.986	4.40	1	0.0044	0.1273	3.232	0.323	4.31	0.00431	431	0.431	0.00043
14.22	0.968	394.1	100,010	1,001	227.6	1	28.96	735.6	73.56	890.7	0.981	98,067	98.07	0.0981
0.04912	0.03342	13.61	345.7	34.57	7.858	0.0345	1	25.4	2.54	33.86	0.0339	3386	3.386	0.00339
0.01934	0.001316	0.0536	13.61	1.361	0.310	0.00136	0.0394	1	0.1	1.333	0.001333	133.3	0.1333	0.000133
0.1934	0.01316	5.358	136.1	13.61	3.10	0.0136	0.394	10	1	13.33	0.01333	1333	1.333	0.00133
0.0145	0.000987	0.4012	10.21	1.021	0.2321	0.00102	0.0295	0.75	0.075	1	0.001	100	0.1	0.0001
14.504	0.987	401.9	10,210	1,021	232.1	1.02	29.53	750	75	1000	1	100,000	100	0.1
0.000145	0.00001	0.00402	0.102	0.0102	0.00232	0.00001	0.000295	0.0075	0.00075	0.01	0.00001	1	0.001	0.000001
0.14504	0.00987	401.9	102.07	10.207	2.321	0.0102	0.295	7.05	0.75	10	0.01	1,000	1	0.001
145.04	9.869	4019	10,2074	10,207	2321	1022.036	295.3	7500	750	10,000	10	1,000,000	1,000	1

Limitation of Liability

The purchaser shall inspect the goods upon receipt to determine that they are free of any defects or deficiencies. If the purchaser is not satisfied with the validity of the goods delivered, please notify WGI.

Claims on defective products do not apply to products which have been subject to misuse, neglect, and accident. The issuing of credit or replacement of goods deemed to be defective is WGI's sole obligation and in no event, shall WGI's liability exceed the purchaser's original purchase price.

Return Policy

A Return Goods Authorization (RGA) number is required for any refund or replacement and is valid for 45 days. All goods must be shipped freight prepaid and must be received by WGI during this period of time. A credit will be issued upon proper inspection and documentation.

WGI Classic Series Pressure Gauges (Dry)



WGI classic series pressure gauges are for general service applications where cost savings are needed. WGI classic series gauges are used in many different applications such as pumping systems, hydraulic or pneumatic systems, compressor packages and as a contractors gauge.

Specifications

Case Material
Black Case - Power Coated

Fill Fluid
None

Lens Material
Glass

Dial
White aluminum with black and red lettering (UV resistant paint)

Pointer
Black aluminum

Accuracy
± 3%-2%-3% ASME B40.1 Grade B

Tube & Socket
Brass tube soldered to brass socket

Temperature Limits
-20°C (-4°F) — 70°C (158°F) ambient and medium

Pressure Ranges
-30" Hg Vacuum to 1,000 PSI / kPa

Sizes
1½", 2", 2½", 3½", 4"



Index

BTM = Bottom Mount
CBM = Center Back
CBU = Center Back U-Clamp
LBU = Lower Back U-Clamp

Dimensions: mm / inch

	Classic 150		Classic 200				Classic 250			Classic 350		Classic 400
Connection	1/8" BTM	1/8" CBM	1/4" BTM	1/8" CBM	1/4" CBM	1/4" CBU	1/4" BTM	1/4" CBM	1/4" CBU	1/4" BTM	1/4" CBU	1/4" BTM
Pressure Ranges	1½" Dial	1½" Dial	2" Dial	2" Dial	2" Dial	2" Dial	2½" Dial	2½" Dial	2½" Dial	3½" Dial	3½" Dial	4" Dial
30" Hg Vac	WJ0405	WJ0605	WJ1405	*N/S	WJ2005	WJ2605	WJ4605	*N/S	WJ6205	WJ8005	WJ8805	N/A
30" Hg x 30 PSI	WJ0412	WJ0612	WJ1412	*N/S	WJ2012	WJ2612	WJ4612	*N/S	WJ6212	WJ8012	WJ8812	N/A
30" Hg x 160 PSI	*N/S	*N/S	*N/S	*N/S	WJ2018	WJ2618	WJ4618	*N/S	WJ6218	WJ8018	WJ8818	N/A
30" Hg x 300 PSI	*N/S	*N/S	*N/S	*N/S	*N/S	WJ2624	WJ4624	*N/S	WJ6224	WJ8024	WJ8824	N/A
0-15 PSI / kPa	WJ0440	WJ0640	WJ1440	N/S	WJ2040	WJ2640	WJ4640	WJ5440	WJ6240	WJ8040	WJ8840	N/A
0-30 PSI / kPa	WJ0442	WJ0642	WJ1442	WJ1842	WJ2042	WJ2642	WJ4642	WJ5442	WJ6242	WJ8042	WJ8842	WJ9042
0-60 PSI / kPa	WJ0446	WJ0646	WJ1446	WJ1846	WJ2046	WJ2646	WJ4646	WJ5446	WJ6246	WJ8046	WJ8846	WJ9046
0-100 PSI / kPa	WJ0448	WJ0648	WJ1448	WJ1848	WJ2048	WJ2648	WJ4648	WJ5448	WJ6248	WJ8048	WJ8848	WJ9048
0-160 PSI / kPa	WJ0452	WJ0652	WJ1452	WJ1852	WJ2052	WJ2652	WJ4652	WJ5452	WJ6252	WJ8052	WJ8852	WJ9052
0-200 PSI / kPa	WJ0454	WJ0654	WJ1454	WJ1854	WJ2054	WJ2654	WJ4654	WJ5454	WJ6254	WJ8054	WJ8854	WJ9054
0-300 PSI / kPa	WJ0458	WJ0658	WJ1458	*N/S	WJ2058	WJ2658	WJ4658	*N/S	WJ6258	WJ8058	WJ8858	WJ9058
0-400 PSI / kPa	WJ0460	WJ0660	WJ1460	*N/S	WJ2060	WJ2660	WJ4660	*N/S	WJ6260	WJ8060	WJ8860	*N/S
0-600 PSI / kPa	WJ0464	WJ0664	WJ1464	*N/S	WJ2064	WJ2664	WJ4664	*N/S	WJ6264	WJ8064	WJ8864	*N/S
0-1,000 PSI / kPa	WJ0472	WJ0672	WJ1472	*N/S	WJ2072	WJ2672	WJ4672	*N/S	WJ6272	WJ8072	WJ8872	*N/S

* Not in Stock

Dimensions

Classic Series – Bottom, Center Back Mount and U-Clamp

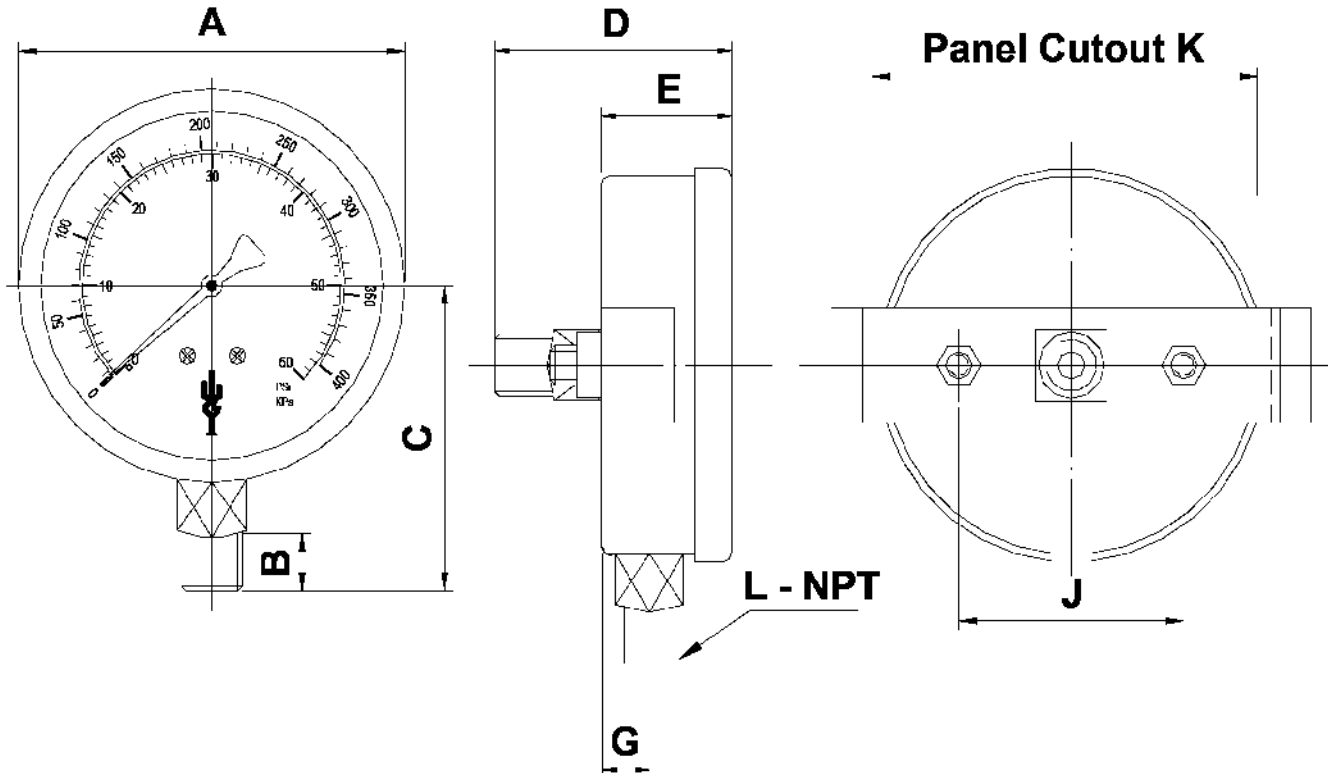

Dimensions: mm / inch

Series	A	B	C	D	E	G	J	K	L
WJ04	42 / 1.65	10.0 / 0.39	34.0 / 1.3	N/A	23.0 / 0.9	8.0 / 0.3	N/A	N/A	1/4" NPT
WJ06	42 / 1.65	10.0 / 0.39	N/A	41.0 / 1.6	25.0 / 0.98	N/A	N/A	N/A	1/4" NPT
WJ14	52.5 / 2.06	10.0 / 0.39	46.0 / 1.8	N/A	28.0 / 1.1	10.0 / 0.4	N/A	N/A	1/4" NPT
WJ18	52.5 / 2.06	12.0 / 0.47	N/A	48.0 / 1.8	28.0 / 1.1	N/A	N/A	N/A	1/4" NPT
WJ20	52.5 / 2.06	12.0 / 0.47	N/A	48.0 / 1.8	28.0 / 1.1	N/A	N/A	N/A	1/4" NPT
WJ26	58.0 / 2.2	12.0 / 0.47	N/A	48.0 / 1.8	30.0 / 1.18	N/A	35	51.5 / 2.0	1/4" NPT
WJ46	68.0 / 2.6	12.0 / 0.47	50.0 / 1.9	N/A	28.0 / 1.1	10.0 / 0.4	N/A	N/A	1/4" NPT
WJ54	68.0 / 2.6	12.0 / 0.47	N/A	48.0 / 1.8	28.0 / 1.1	N/A	N/A	N/A	1/4" NPT
WJ62	68.0 / 2.6	12.0 / 0.47	N/A	48.0 / 1.8	30.0 / 1.18	N/A	48	62.5 / 2.0	1/4" NPT
WJ80	89.0 / 3.5	12.0 / 0.47	50.0 / 1.9	N/A	29.0 / 1.14	12.0 / 0.47	N/A	N/A	1/4" NPT
WJ88	98.0 / 3.8	12.0 / 0.47	N/A	51.0 / 2.0	32.0 / 1.2	N/A	75	88.0 / 3.4	1/4" NPT
WJ90	100.5 / 3.95	13 / 0.51	75 / 2.9	N/A	34 / 1.33	23.5 / 0.92	N/A	N/A	1/4" NPT

WGI Elite Brass Series Pressure Gauges (Liquid Filled)



WGI elite series brass pressure gauges have a 304 stainless steel case for use in harsh or corrosive environments. These gauges are liquid filled for significant cushioning and pulsation dampening which reduces pointer flutter and internal damage. Industries suited for these gauges include oil and gas equipment, refineries, hydraulic equipment, agricultural equipment, pressure washers, pumps, compressors and process systems.



Specifications

Case Material
304 SS, top nitrile vent plug with valve and lens seal

Fill Fluid
Silicone

Lens Material
Acrylic and safety glass (ranges over 5,000 PSI)

Dial
White aluminum with black and red lettering (UV Resistant Paint)

Pointer
Black aluminum

Accuracy
± 2%-1%-2% ASME B40.1 Grade A

Tube & Socket
Brass tube silver soldered to brass socket

Temperature Limits
-76°F — 158°F (-60°C — 70°C) ambient and medium

Pressure Ranges
-30" Hg Vacuum to 10,000 PSI / kPa

Sizes
2½", 4"

Three Hole Front Flange	
Part Number 2 ½" Dial	Part Number 4" Dial
127751	127754

Index

BTM = Bottom Mount
CBM = Center Back
CBU = Center Back U-Clamp
LBU = Lower Back U-Clamp

Connection	Elite 250 Brass		Elite 400 Brass	
	¼" BTM	¼" CBU	¼" BTM	¼" LBU
Pressure Ranges				
30" Hg Vac / -kPa	WJ7605P	WJ7205P	WH10105P	WH10305P
30" Hg x 15 PSI / kPa	WJ7610P	WJ7210P	WH10110P	WH10310P
30" Hg x 30 PSI / kPa	WJ7612P	WJ7212P	WH10112P	WH10312P
30" Hg x 60 PSI / kPa	WJ7614P	WJ7214P	WH10114P	WH10314P
30" Hg x 100 PSI / kPa	WJ7616P	WJ7216P	WH10116P	WH10316P
30" Hg x 150 PSI / kPa	WJ7618P	WJ7218P	WH10118P	WH10318P
30" Hg x 300 PSI / kPa	WJ7624P	WJ7224P	WH10124P	WH10324P
0-15 PSI / kPa	WJ7640P	WJ7240P	WH10140P	WH10340P
0-30 PSI / kPa	WJ7642P	WJ7242P	WH10142P	WH10342P
0-60 PSI / kPa	WJ7646P	WJ7246P	WH10146P	WH10346P
0-100 PSI / kPa	WJ7648P	WJ7248P	WH10148P	WH10348P
0-160 PSI / kPa	WJ7652P	WJ7252P	WH10152P	WH10352P
0-200 PSI / kPa	WJ7654P	WJ7254P	WH10154P	WH10354P
0-300 PSI / kPa	WJ7658P	WJ7258P	WH10158P	WH10358P
0-400 PSI / kPa	WJ7660P	WJ7260P	WH10160P	WH10360P
0-600 PSI / kPa	WJ7664P	WJ7264P	WH10164P	WH10364P
0-800 PSI / kPa	WJ7668P	WJ7268P	WH10168P	WH10368P
0-1,000 PSI / kPa	WJ7672P	WJ7272P	WH10172P	WH10372P
0-1,500 PSI / kPa	WJ7674P	WJ7274P	WH10174P	WH10374P
0-2,000 PSI / kPa	WJ7676P	WJ7276P	WH10176P	WH10376P
0-3,000 PSI / kPa	WJ7678P	WJ7278P	WH10178P	WH10378P
0-5,000 PSI / kPa	WJ7682P	WJ7282P	WH10182P	WH10382P
0-6,000 PSI / kPa	WJ7684P	WJ7284P	WH10184P	WH10384P
0-7,500 PSI / kPa	WJ7686P	WJ7286P	WH10186P	WH10386P
0-10,000 PSI / kPa	WJ7690P	WJ7290P	WH10190P	WH10390P

WGI Elite Brass Series Pressure Gauges (Liquid Filled)



Dimensions

Dimensions: mm / inch

Elite 250 Brass – Bottom Mount

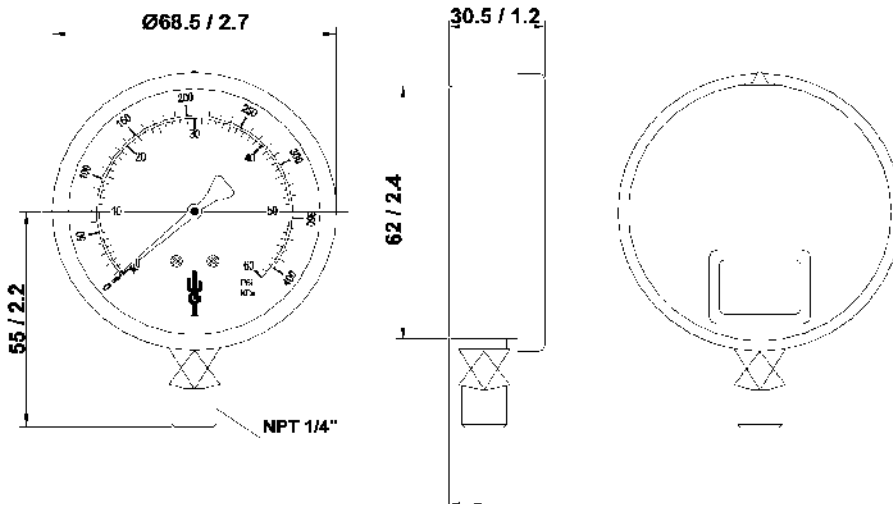

Elite 250 – Back Mount U-Clamp

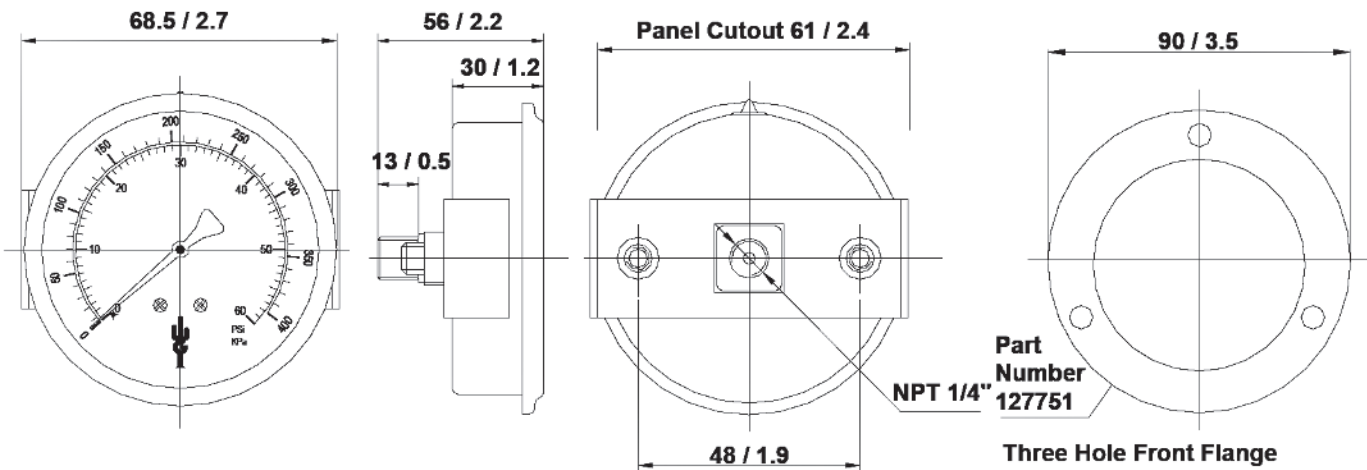

Elite 400 – Lower Back U-Clamp & Bottom Mount

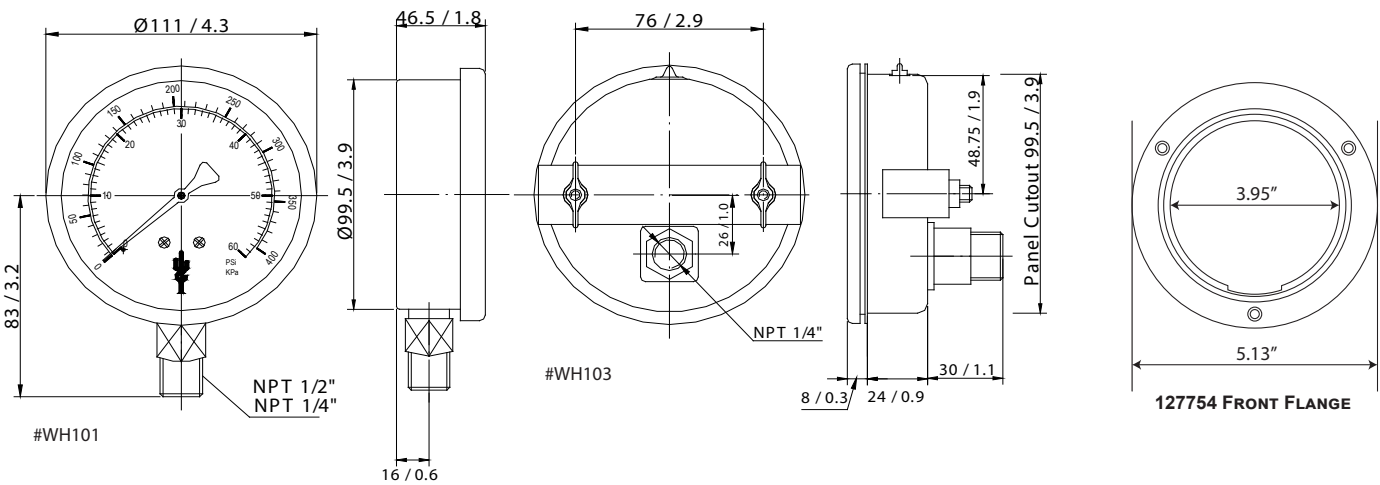

WGI Elite Stainless Steel Series Pressure Gauges (Liquid Filled)



WGI elite series brass pressure gauges have a 304 stainless steel case for use in harsh or corrosive environments. These gauges are liquid filled for significant cushioning and pulsation dampening which reduces pointer flutter and internal damage. Industries suited for these gauges include oil and gas equipment, refineries, hydraulic equipment, agricultural equipment, pressure washers, pumps, compressors and process systems.

Specifications

- Case Material**
304 SS, top nitrile vent plug with valve and lens seal
- Fill Fluid**
Silicone
- Lens Material**
Acrylic and safety glass (safety glass standard on WH109)
- Dial**
White aluminum with black and red lettering (UV Resistant Paint)
- Pointer**
Black aluminum
- Accuracy**
Elite 150/250 ± 2%-1%-2% ASME B40.1 Grade B
Elite 600 + 400 ± 1% full scale ASME B40.1 Grade A
- Tube & Socket**
316L SS NACE MR 0175
- Temperature Limits**
-76°F — 158°F (-60°C — 70°C) ambient and medium
- Pressure Ranges**
-30" Hg Vacuum to 15,000 PSI / kPa
- Sizes**
1½", 2", 2½", 4", 6"



Connection	Elite 150		Elite 200		Elite 250		Elite 400		Elite 400	Elite 600
	1/8" BTM	1/8" CBM	1/4" BTM	1/4" CBM	1/4" BTM	1/4" CBU	1/4" BTM	1/4" LBU	1/2" BTM	1/2" BTM
Pressure Ranges	1½" Dial	1½" Dial	2" Dial	2" Dial	2½" Dial	2½" Dial	4" Dial	4" Dial	4" Dial	6" Dial
30" Hg Vac / -kPa	*N/S	*N/S	*N/S	*N/S	WJ7805P	WJ7405P	WH10705P	WH10805P	WH10905P	WH20905P
30" Hg x 15 PSI / kPa	*N/S	*N/S	*N/S	*N/S	WJ7810P	WJ7410P	WH10710P	WH10810P	WH10910P	WH20910P
30" Hg x 30 PSI / kPa	*N/S	*N/S	*N/S	*N/S	WJ7812P	WJ7412P	WH10712P	WH10812P	WH10912P	WH20912P
30" Hg x 60 PSI / kPa	*N/S	*N/S	*N/S	*N/S	WJ7814P	WJ7414P	WH10714P	WH10814P	WH10914P	WH20914P
30" Hg x 100 PSI / kPa	*N/S	*N/S	*N/S	*N/S	WJ7816P	WJ7416P	WH10716P	WH10816P	WH10916P	WH20916P
30" Hg x 150 PSI / kPa	*N/S	*N/S	*N/S	*N/S	WJ7818P	WJ7418P	WH10718P	WH10818P	WH10918P	WH20918P
30" Hg x 300 PSI / kPa	*N/S	*N/S	*N/S	*N/S	WJ7824P	WJ7424P	WH10724P	WH10824P	WH10924P	WH20924P
0-15 PSI / kPa	*N/S	*N/S	*N/S	*N/S	WJ7840P	WJ7440P	WH10740P	WH10840P	WH10940P	WH20940P
0-30 PSI / kPa	WJ1142P	WJ1042P	WJ1342P	WJ1542P	WJ7842P	WJ7442P	WH10742P	WH10842P	WH10942P	WH20942P
0-60 PSI / kPa	WJ1146P	WJ1046P	WJ1346P	WJ1546P	WJ7846P	WJ7446P	WH10746P	WH10846P	WH10946P	WH20946P
0-100 PSI / kPa	WJ1148P	WJ1048P	WJ1348P	WJ1548P	WJ7848P	WJ7448P	WH10748P	WH10848P	WH10948P	WH20948P
0-160 PSI / kPa	WJ1152P	WJ1052P	WJ1352P	WJ1552P	WJ7852P	WJ7452P	WH10752P	WH10852P	WH10952P	WH20952P
0-200 PSI / kPa	WJ1154P	WJ1054P	WJ1354P	WJ1554P	WJ7854P	WJ7454P	WH10754P	WH10854P	WH10954P	WH20954P
0-300 PSI / kPa	WJ1158P	WJ1058P	WJ1358P	WJ1558P	WJ7858P	WJ7458P	WH10758P	WH10858P	WH10958P	WH20958P
0-400 PSI / kPa	*N/S	*N/S	*N/S	*N/S	WJ7860P	WJ7460P	WH10760P	WH10860P	WH10960P	WH20960P
0-500 PSI / kPa	*N/S	*N/S	*N/S	*N/S	WJ7862P	WJ7462P	WH10762P	WH10862P	WH10962P	WH20962P
0-600 PSI / kPa	*N/S	*N/S	*N/S	*N/S	WJ7864P	WJ7464P	WH10764P	WH10864P	WH10964P	WH20964P
0-800 PSI / kPa	*N/S	*N/S	*N/S	*N/S	WJ7868P	WJ7468P	WH10768P	WH10868P	WH10968P	WH20968P
0-1,000 PSI / kPa	*N/S	*N/S	*N/S	*N/S	WJ7872P	WJ7472P	WH10772P	WH10872P	WH10972P	WH20972P
0-1,500 PSI / kPa	*N/S	*N/S	*N/S	*N/S	WJ7874P	WJ7474P	WH10774P	WH10874P	WH10974P	WH20974P
0-2,000 PSI / kPa	*N/S	*N/S	*N/S	*N/S	WJ7876P	WJ7476P	WH10776P	WH10876P	WH10976P	WH20976P
0-3,000 PSI / kPa	*N/S	*N/S	*N/S	*N/S	WJ7878P	WJ7478P	WH10778P	WH10878P	WH10978P	WH20978P
0-5,000 PSI / kPa	*N/S	*N/S	*N/S	*N/S	WJ7882P	WJ7482P	WH10782P	WH10882P	WH10982P	WH20982P
0-6,000 PSI / kPa	*N/S	*N/S	*N/S	*N/S	WJ7884P	WJ7484P	WH10784P	WH10884P	WH10984P	WH20984P
0-7,500 PSI / kPa	*N/S	*N/S	*N/S	*N/S	WJ7886P	WJ7486P	WH10786P	WH10886P	WH10986P	WH20986P
0-10,000 PSI / kPa	*N/S	*N/S	*N/S	*N/S	WJ7890P	WJ7490P	WH10790P	WH10890P	WH10990P	WH20990P
0-20,000 PSI / kPa	*N/S	*N/S	*N/S	*N/S	*N/S	*N/S	*N/S	WH10894P	WH10994P	*N/S

* Not in Stock

Dimensions

Dimensions: mm / inch

Elite 150 Stainless Steel – Center Back Mount

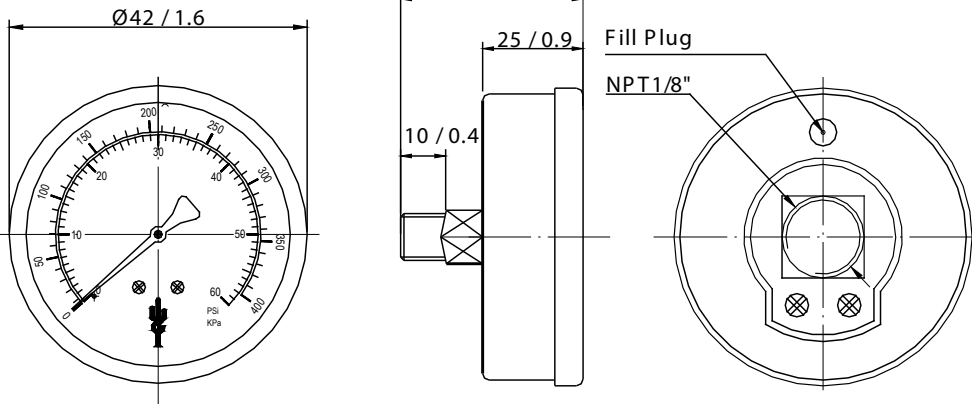

Elite 200 Stainless – Bottom Mount

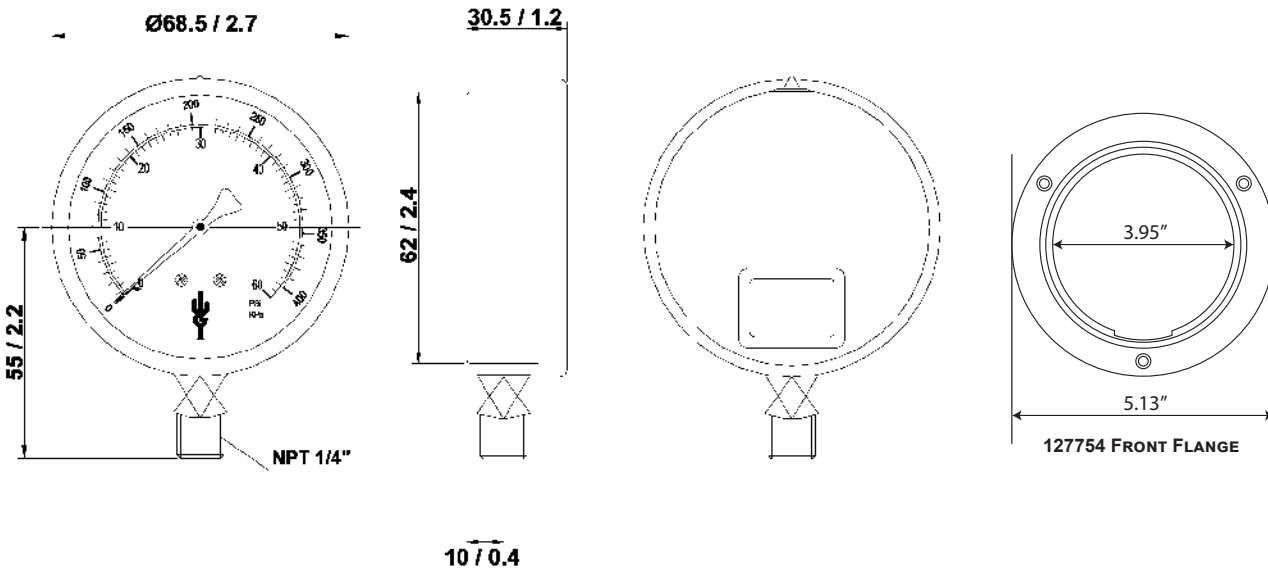

Elite 250 Stainless Steel – Bottom Mount & U-Clamp

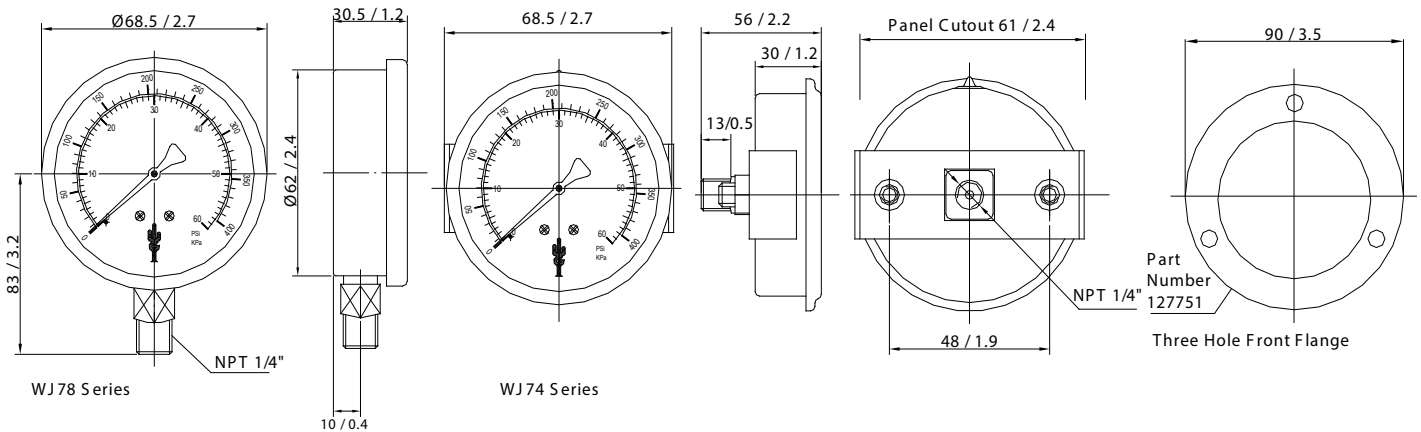

Dimensions

Dimensions: mm / inch

Elite 400 Stainless Steel – Lower Back U-Clamp & Bottom Mount

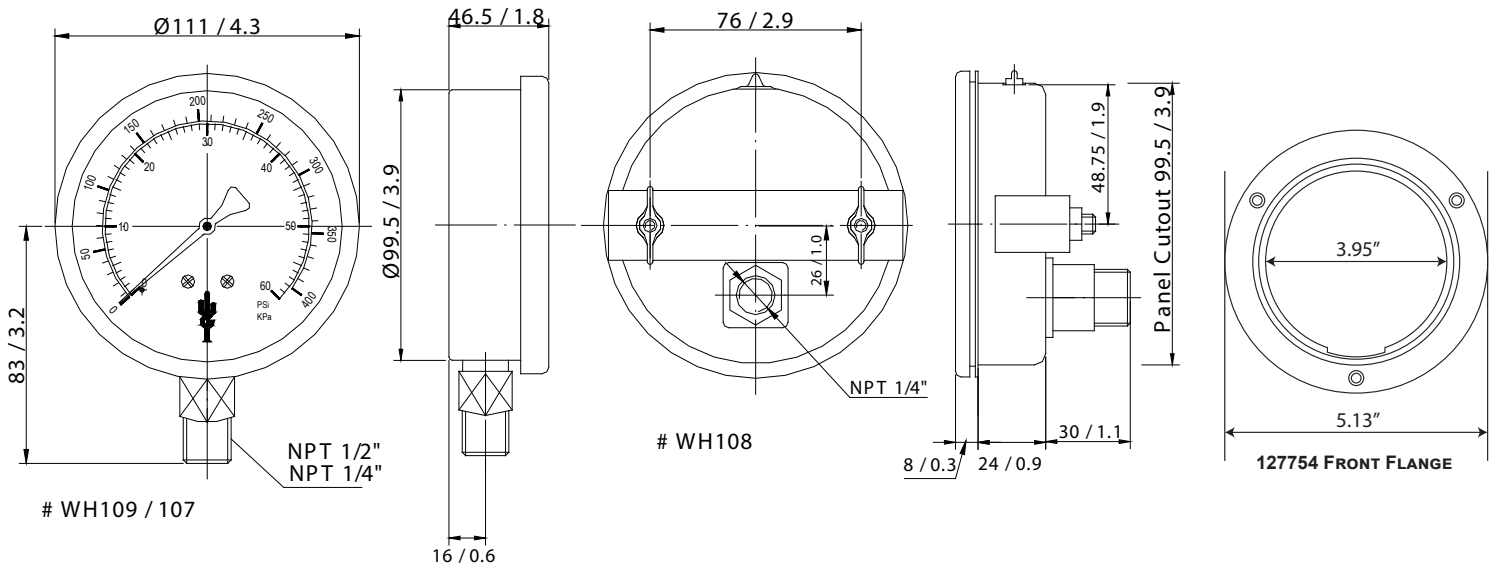

Elite 600 Stainless – Bottom Mount

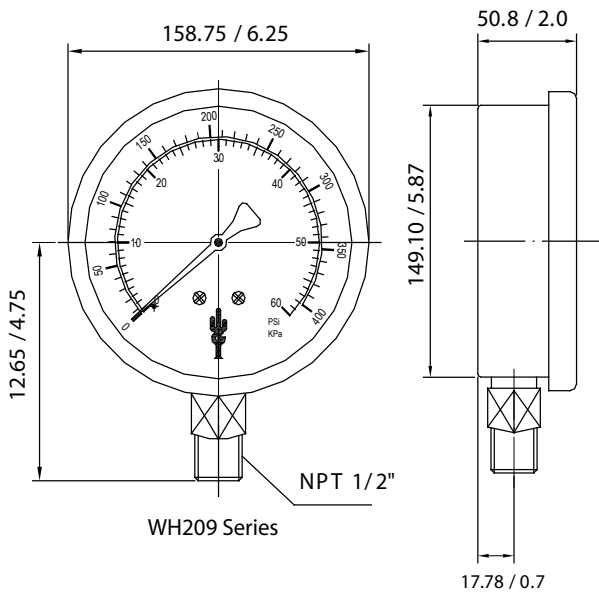

WGI Elite 450 Process Pressure Gauges (NACE)



WGI elite 450 process gauge is engineered for the oil and gas and industrial process industries. The WGI elite 450 process gauge was designed with the operator's safety in mind. In the event of over-pressuring resulting in a leak, a solid wall separates the rupture forcing the process media through blowing out the back of the gauge.

Specifications

Case Material

Polypropylene safe case solid front with blowout back

Fill Fluid

Silicone

Lens Material

Acrylic

Dial

White aluminum with black and red lettering (UV Resistant Paint)

Pointer

Black aluminum

Accuracy

± 1.0% ASME B40.1 Grade 1A

Tube & Socket

316L SS

Temperature Limits

-40°F — 140°F (-40°C — 60°C) ambient and medium

Pressure Ranges

-30" Hg Vacuum to 20,000 PSI / kPa

Size

4½"

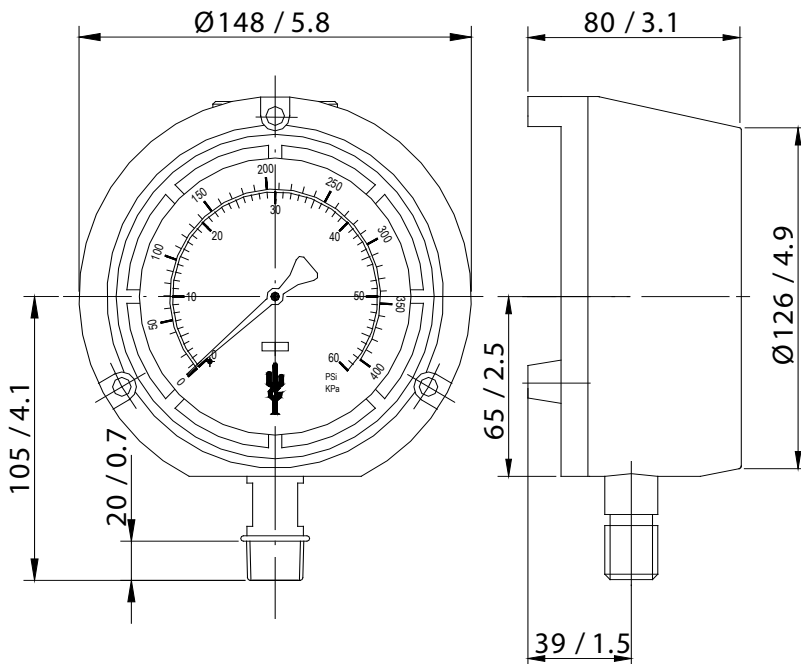

	Elite 450	Elite 450
Connection	* 1/4" BTM	1/2" BTM
Pressure Ranges	4½" Dial	4½" Dial
30" Hg Vac / kPa	WP5105P	WP5605P
30" Hg x 15 PSI / kPa	WP5110P	WP5610P
30" Hg x 30 PSI / kPa	WP5112P	WP5612P
30" Hg x 60 PSI / kPa	WP5114P	WP5614P
30" Hg x 100 PSI / kPa	WP5116P	WP5616P
30" Hg x 150 PSI / kPa	WP5118P	WP5618P
30" Hg x 300 PSI / kPa	WP5124P	WP5624P
0-15 PSI / kPa	WP5140P	WP5640P
0-30 PSI / kPa	WP5142P	WP5642P
0-60 PSI / kPa	WP5146P	WP5646P
0-100 PSI / kPa	WP5148P	WP5648P
0-160 PSI / kPa	WP5152P	WP5652P
0-200 PSI / kPa	WP5154P	WP5654P
0-300 PSI / kPa	WP5158P	WP5658P
0-400 PSI / kPa	WP5160P	WP5660P
0-600 PSI / kPa	WP5164P	WP5664P
0-1,000 PSI / kPa	WP5172P	WP5672P
0-1,500 PSI / kPa	WP5174P	WP5674P
0-2,000 PSI / kPa	WP5176P	WP5676P
0-3,000 PSI / kPa	WP5178P	WP5678P
0-5,000 PSI / kPa	WP5182P	WP5682P
0-6,000 PSI / kPa	WP5184P	WP5684P
0-7,500 PSI / kPa	WP5186P	WP5686P
0-10,000 PSI / kPa	WP5190P	WP5690P
0-15,000 PSI / kPa	WP5192P	WP5692P
0-20,000 PSI / kPa	WP5194P	WP5694P

* Not in Stock

WGI Elite 450 All Stainless Safe Case



WGI elite 450 process gauge has been engineered specifically for the oil and gas industrial process sector. This process gauge was designed with an operator's safety in mind. There is a metal plate inside the gauge that ensures that if a rupture occurs, the process will blow out the back of the case versus forward thus preventing any process being directed at the operator.

Specifications

Size
4½" (115mm) Dial

Fill Fluid
Silicone (other fill fluids available upon request)

Lens (Window) Material
Laminated safety glass

Dial
White aluminum with black and red numerals

Pointer
Micrometer adjustable black aluminum

Accuracy
± 1.0% ASME B40.1 Grade 1A

Bourdon Tube & Socket
316L SS tube welded to stainless socket
Internal components are heat treated to conform to NACE MRO-175-2003

Temperature Limits
-76°F — 158°F (-60°C — 70°C) ambient and medium

Pressure Ranges
-30" Hg Vacuum to 20,000 PSI / kPa

Case Type / Material
Solid front, blowout back, 304 SS Case

Ring Type / Material
Screw-on, 304 SS

Ranges (all ranges not stocked)
Vacuum / Compound to 30" Hg / 0 / 60 PSI
Pressure from 15 PSI to 20,000 PSI

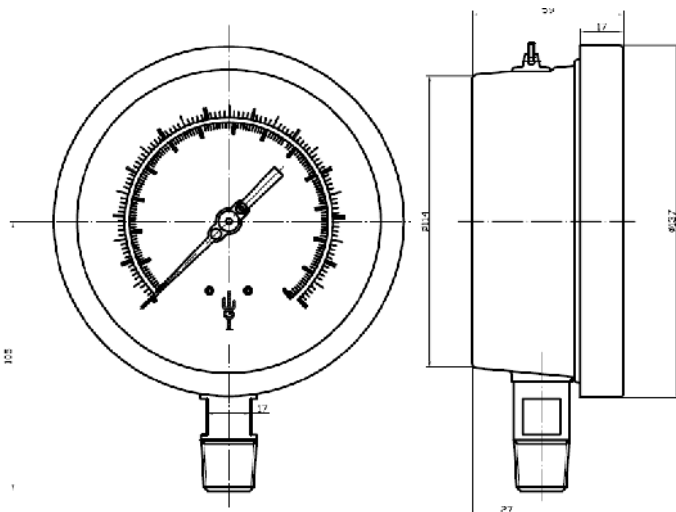

Elite 450 Stainless		
Connection	*1/4" BTM	1/2" BTM
Pressure Ranges	Bottom	Bottom
30" Hg Vac / -100 kPa	WP6105P	WP6605P
30" Hg x 30 PSI / -100 to 210 kPa	WP6112P	WP6612P
30" Hg x 60 PSI / -100 to 420 kPa	WP6114P	WP6614P
30" Hg x 100 PSI / -100 to 700 kPa	WP6116P	WP6616P
30" Hg x 160 PSI / -100 to 1,100 kPa	WP6118P	WP6618P
30" Hg x 300 PSI / -100 to 21,00 kPa	WP6124P	WP6624P
0-15 PSI / 105 kPa	WP6140P	WP6640P
0-30 PSI / 210 kPa	WP6142P	WP6642P
0-60 PSI / 420 kPa	WP6146P	WP6646P
0-100 PSI / 700 kPa	WP6148P	WP6648P
0-160 PSI / 1,100 kPa	WP6152P	WP6652P
0-200 PSI / 1,400 kPa	WP6154P	WP6654P
0-300 PSI / 2,100 kPa	WP6158P	WP6658P
0-400 PSI / 2,800 kPa	WP6160P	WP6660P
0-600 PSI / 4,200 kPa P	WP6164P	WP6664
0-1,000 PSI / 7,000 kPa	WP6172P	WP6672P
0-1,500 PSI / 10,000 kPa	WP6174P	WP6674P
0-2,000 PSI / 14,000 kPa	WP6176P	WP6676P
0-30,000 PSI / 21,000 kPa	WP6178P	WP6678P
0-5,000 PSI / 35,000 kPa	WP6182P	WP6682P
0-6,000 PSI / 42,000 kPa	WP6184P	WP6684P
0-7,500 PSI / 52,000 kPa	WP6186P	WP6686P
0-100,00 PSI / 70,000 kPa	WP6190P	WP6690P
0-15,000 PSI / 105,000 kPa	WP6192P	WP6692P
0-20,000 PSI / 130,000 kPa	WP6194P	WP6694P

* Not in Stock

WGI diaphragm gauges are sensitive instruments used in low pressure applications not exceeding 10 PSI. The diaphragm capsule is an elastic metal sensing element comprised of two thin wall diaphragms that are soldered together to make the capsule. Typical applications include air flow indicators, liquid level indicators, leak testers, natural gas gauges and any other application that requires precise measurement of pressures below 10 PSI.

Specifications

Case Material
Drawn Steel

Fill Fluid
None

Lens Material
Acrylic

Dial
White aluminum with black lettering

Pointer
Black aluminum

Accuracy
± 2-1-2% Full scale

Internals & Diaphragm
Brass & 316 SS

Temperature Limits
-4°F — 140°F (-20°C — 60°C) ambient and medium

Pressure Ranges
-100" H₂O Vacuum to 10 PSI

Sizes
2½" and 4"

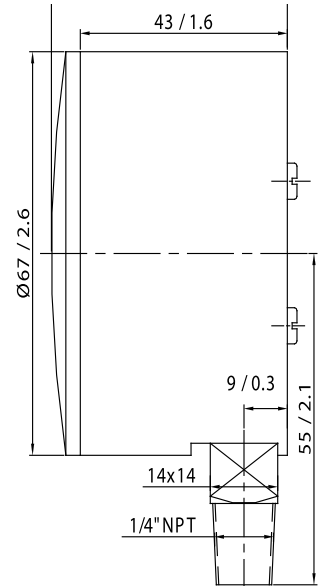

2 1/2" Dial	1/4" BTM	1/4" BTM
Pressure Ranges	Brass	316 SS
0-10" H ₂ O / 2.5 kPa	WG22675	*N/S
0-15" H ₂ O / 8.75 OZ / 3.7 kPa	WG22706	WG22706SS
0-15" H ₂ O / 3.7 kPa	WG24500	*N/S
0-30" H ₂ O / 7.5 kPa	WG22704	*N/S
0-35" H ₂ O / 20 OZ / 8.6 kPa	WG22709	WG22709SS
0-55" H ₂ O / 32 OZ / 13.8 kPa	WG22707	WG22707SS
0-100" H ₂ O / 58 OZ / 25 kPa	WG22710	WG22710SS
0-3 PSI / 20 kPa	WG22685	WG22685SS
0-5 PSI / 34 kPa	WG22702	WG22702SS
0-10 PSI / 69 kPa	WG22699	WG22699SS

4" Dial	1/4" BTM	1/4" BTM	1/2" BTM	1/2" BTM
Pressure Ranges	Brass	316 SS	Brass	316 SS
0-10" H ₂ O / 2.5 kPa	WG41675	*N/S	WG42675	*N/S
0-15" H ₂ O / 8.75 OZ / 3.7 kPa	WG41706	WG41706SS	WG42706	WG42706SS
0-15" H ₂ O / 3.7 kPa	WG41500	*N/S	WG42500	*N/S
0-30" H ₂ O / 7.5 kPa	WG41704	*N/S	WG42704	*N/S
0-35" H ₂ O / 20 OZ / 8.6 kPa	WG41709	WG41709SS	WG42709	WG42709SS
0-55" H ₂ O / 32 OZ / 13.8 kPa	WG41707	WG41707SS	WG42707	WG42707SS
0-100" H ₂ O / 58 OZ / 25 kPa	WG41710	WG41710SS	WG42710	WG42710SS
0-3 PSI / 20 kPa	WG41685	WG41685SS	WG42685	WG42685SS
0-5 PSI / 34 kPa	WG41702	WG41702SS	WG42702	WG42702SS
0-10 PSI / 69 kPa	WG41699	WG41699SS	WG42699	WG42699SS
0-30" H ₂ O VAC x 50" H ₂ O	*N/S	*N/S	WG42913	WG42913SS

* Not in Stock

2 1/2" Dial	1/4"	1/4"
Vacuum Ranges & Compound Ranges	Part Numbers	316 SS
0-30" H ₂ O / VAC x 50" H ₂ O	WG22913	*N/S
0-15" H ₂ O / VAC / - kPa	WG22912	*N/S
0-30" H ₂ O / VAC / - kPa	WG22914	*N/S
0-60" H ₂ O / VAC / - kPa	WG22918	*N/S
0-100" H ₂ O / VAC / - kPa	WG24502	*N/S

A low cost differential pressure gauge for use in measuring the pressure drop across filters, strainers, separators, valves, pumps, chillers, etc. and for local flow indication and control.

Mid-West[®]
Instrument

Specifications

Case Material
Plastic (standard) / aluminum 316 SS

Fill Fluid
Glycerin (optional)

Lens Material
Shatter resistant acrylic

Dial
White aluminum with black lettering

Pointer
Black aluminum

Accuracy
± 3-2-3% Full scale (ascending)

Wetted Parts
Aluminum or 316 SS

Temperature Limits
-40°F — 200°F 93° (-40°C — 93°C) ambient and medium

Pressure Ranges
0-5 through 0-110 PSID (0.35 to 7.0 bar)

Sizes
2½" and 4½"



Differential pressure is sensed by the movement of a floating piston magnet against a calibrated spring. The gauge pointer, outside the pressure housing, follows the movement of the piston magnet and indicates differential pressure.

Available with magnetically actuated hermetically sealed CSA listed reed switches to provide high and low limit alarm or control.



An optional maximum indication follower pointer provides automatic indication of maximum differential occurring during a time period or system cycle.

Reversed pressure ports are available as an option when installing for readability depending on which side of a filter, etc.,

***Additional series are available.

WGI's fire protection sprinkler gauges are UL listed and FM approved and are ideally suited for fire sprinkler systems.

Specifications

Case Material
Black plastic

Lens Material
Polycarbonate

Dial
White aluminum with black

Pointer
Black aluminum

Accuracy
3-2-3% ASME Grade B

Tube & Socket
Copper alloy / brass

Temperature Limits
-4°F — 140°F (-20°C to 60°C) ambient and medium

Pressure Ranges
0-300 PSI / kPa

Size
4"



Part Number	Range
Spinkler-Water-300	0-300 PSI

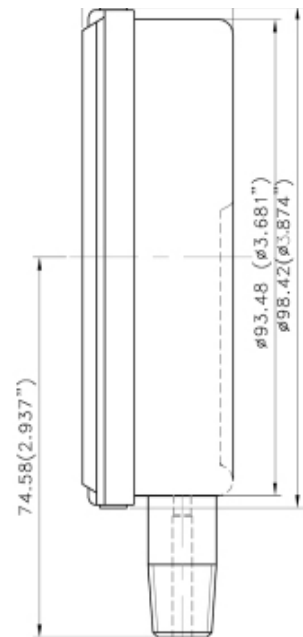
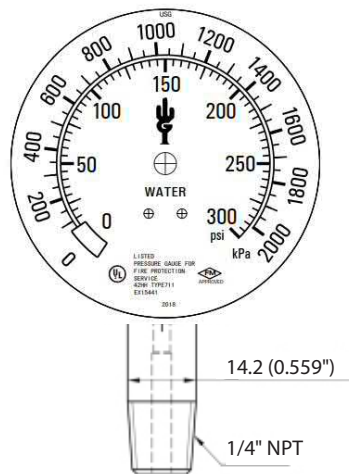

The WGI agricultural ammonia pressure gauge is specifically designed to withstand all the punishment involved in manufacturing, distributing and applying ammonia as an agricultural fertilizer. Typical applications include bulk storage tanks, field tanks, processing equipment, metering devices and applicator equipment.

Specifications

Case Material
Corrosion resistant steel case and ring / 304 SS

Fill Fluid
Dry or silicon

Lens Material
Acrylic or glass

Dial
White aluminum with black lettering

Pointer
Black aluminum

Accuracy
± 3%-2%-3% ASME B40.1 Grade B

Tube & Socket
Bourdon tube 304 SS, Socket carbon steel / 316 SS

Temperature Limits
-4°F — 140°F (-20°C to 60°C) ambient and medium

Sizes
2½" and 4"

Index

BTM = Bottom Mount
CBM = Center Back
CBU = Center Back U-Clamp
LBC = Lower Back Connector

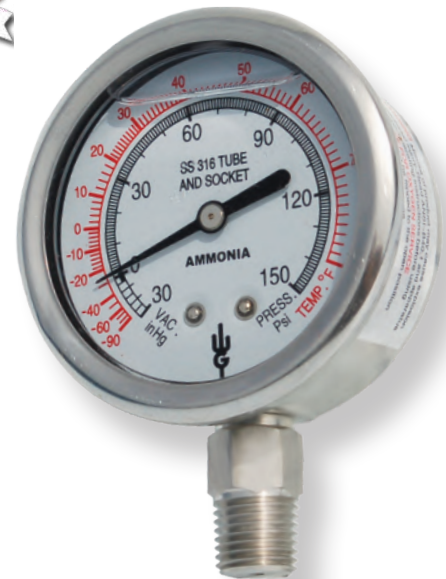

	Agriculture	
Dial Size	2½" Dial	4" Dial
Connection	1/4" NPT BTM	1/4" NPT BTM
Pressure Ranges		
0-60 PSI	WW0160	WW0260
0-150 PSI	WW0162	WW0262
0-400 PSI	WW0164	WW0264

	Refrigeration				
Dial Size	2½" Dial	2½" Dial	4" Dial	4" Dial	4" Dial
Connection	1/4" NPT BTM	1/4" NPT CBU	1/4" NPT BTM	1/4" NPT LBU	1/2" NPT BTM
Pressure Ranges					
30" Hg x 150 PSI / kPa	WJ7818PA	WJ7418PA	WH10718PA	WH10818PA	WH10918PA
30" Hg x 300 PSI / kPa	WJ7824PA	WJ7424PA	WH10724PA	WH10824PA	WH10924PA

Front Flange	2½" Dial	4" Dial
	127751	127754

When choosing a diaphragm seal, WGI offers unsurpassed quality, service and delivery. WGI recommends the use of a diaphragm seal for all applications involving, but not limited to corrosive media, (media containing particles), viscous media, temperature issues and the use of oxidizing agents.

Specifications

Fill Fluid

Silicone, high temperature silicone, glycerin

Seal Type

DS90 - 8 Bolt, welded to upper body

DSTB - All welded design

DS-LPVC-PVC bolted

Lower Housing Materials

Optional steel, 304 SS, 316 SS, hastelloy B or C, monel, nickel, PVC, teflon, brass, titanium and polypropylene

Diaphragm Materials

316 SS

Special materials include 304 SS, monel, tantalum, hastelloy B and C, carpenter 20, nickel, titanium and teflon

Optional Features

316 SS top housing with SS rings, nuts and bolts

Pipe plugs for flushing connections

Flange faces - raised or flat face or ring joint

Capillary Lines

If your application requires a stainless steel capillary lines, specify one of the following and your desired length when ordering

- Plain tube 1/4" NPT
- SS plain tube 1/2" NPT
- SS armored 1/4" NPT
- SS armored 1/2" NPT

Sizes

1/4" and 1/2"



Part No.	Instrument Connection	Process Connection	Body Material	Diaphragm Material	Pressure Range
DS90-D-D	1/2" FNPT	1/2" FNPT	316 SS	316 SS	-30 Hg to 2,500 PSI
DSTB-B-B	1/4" FNPT	1/4" FNPT	316 SS	316 SS	-30 Hg to 2,500 PSI
DSTB-B-B	1/2" FNPT	1/2" FNPT	316 SS	316 SS	-30 Hg to 2,500 PSI
DS-LPVC11-T-O	1/4" FNPT	1/4" FNPT	PVC	PTFE	0-200 PSI

WGI White Teflon & Yellow ULC Gas Thread Seal Tape



WGI teflon tape is a rugged inert tape made from 100% pure, virgin PTFE. These tapes can be utilized anywhere there is a requirement for strength, thickness and resistance on threaded connections. It is highly resistant to acids, alkalies, solvents and gases and is clean and easy to use. It keeps its protective qualities indefinitely and adapts to galvanized iron, stainless steel, brass, plastic or fiberglass. It is approved under the Underwriters Laboratory of Canada and meets US Military specification MIL-T-27730A.

Specifications

Thickness

White Tape 0.076mm
Yellow Tape 0.10mm
Pink Tape 0.1mm

Conforms to Military specification T-27730A

ULC Approved - Model GTT (yellow)
CMH1677-ISS.#1C

Service Rating
-400°F — 500°F (-240°C — 260°C)

Pressure Rating
Yellow Gas Tape 2250 PSI

General Purpose White Tape			
Part No.	Length	Size	Color
TT - 1/2	480"	1/2"	White
TT - 3/4	480"	3/4"	White
TT-1	480"	1"	White
ULC Gas Approved Yellow Tape			
Part No.	Length	Size	Color
GTT - 1/2	480"	1/2"	Yellow
GTT - 3/4	480"	3/4"	Yellow
GTT -1	480"	1"	Yellow
Pink Tape			
Part No.	Length	Size	Color
PTT - 1/2	520"	1/2"	Pink
PTT - 3/4	520"	3/4"	Pink
PTT-1	520"	1"	Pink



WGI Rubber Gauge Guards

WGI rubber gauge guards are used to protect pressure gauges from accidental physical damage. Made to fit a 2½" or 4" bottom or back mount pressure gauge.

Part Number	Color
PGG-2.5	Blue
PGG-2.5B	Black
PGG-40	Black



WGI pressure snubbers are designed for use in light oil, water and gas applications to significantly lessen the damaging effects of pulsation on pressure gauges, pressure transducers, transmitters, pressure switches and many other types of pressure instrumentation.

Specifications

Process Connection
1/4" NPT or 1/2" NPT male x female

Material
Brass or 316 SS

Pressure Rating
Brass 3,000 PSI
316 SS 20,000 PSI

Operating Temperature
Brass -65°F — 343°F (-53°C — 343°C)
316 SS -320°F — 1,500°F (-195°C — 815°C)



25B – A50S – A25S

Part No.	Material	P	L
25B	Brass	1/4"	1.376"
A25S	316 SS	1/4"	1.376"
A50S	316 SS	1/2"	1.750"

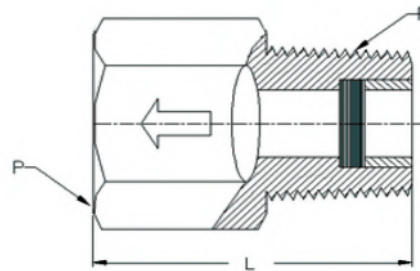

Mid-West Pressure Limiting Valve (Gauge Minder)

The model 200 gauge minder features a pressure limiting valve that blocks off excess pressure to the instrument, preventing calibration failure, internal damage, and blow-out from over-ranging (a principal cause of instrument failure). The model 200 is supplied with a set of range springs designed to set the shutoff pressure point at any pressure from 50 to 5,000 PSI. The automatic shutoff valve is positive on closing and is non-chattering. Once closed, pressure need only be reduced approximately 10% of set pressure to re-open the valve.

Specifications

Connection

1/4" or 1/2" NPT

Body & Stopper Material

Aluminum, brass and 316 SS

Pressure Rating

Up to 10,000 PSI

Operating Temperature

-40°F — 248°F (-40°C — 120°C)

Adjustment

1/4" Allen head adjustment

Accuracy

± 10% of set value

Seals

Buna, viton, teflon, neoprene or special materials

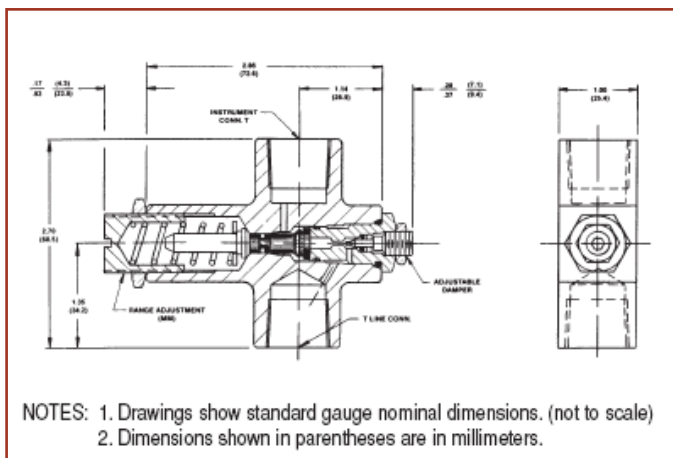

Part Numbering System

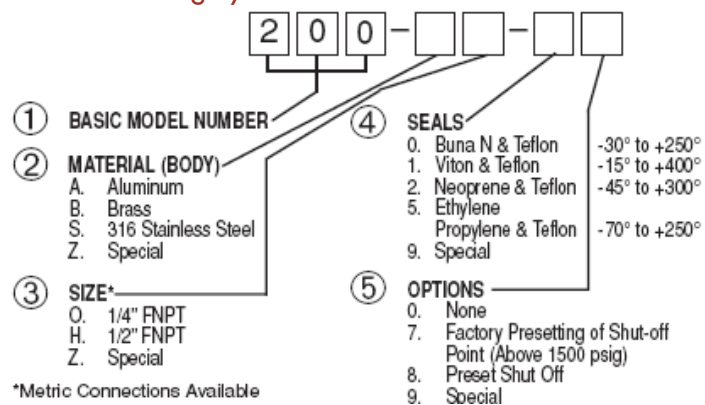

The range springs are identified by color, as follows:

Color of Spring	Shut-off Range, PSI
Silver	50 to 120 PSI
Black	100 to 1100 PSI
Gold	1000 to 5000 PSI

Model	Max. Working Pressure PSIG (kg/cm)	Body Material	T
200AO	5,000 (350)	ALUMINUM	1/4" F.N.P.T.
200BO	5,000 (350)	BRASS	1/4" F.N.P.T.
200SO	5,000 (350)	316 S.S.	1/4" F.N.P.T.
200BH	10,000 (700)	BRASS	1/2" F.N.P.T.
200SH	10,000 (700)	316 S.S.	1/2" F.N.P.T.

Manufacturer reserves the right to change specifications without prior notice.

WGI barrel siphons are a cost effective way to maximize gauge life. WGI barrel siphons are made from solid bar to produce a rigid mount and easy installation. Barrel siphons are used to reduce the temperature of the medium before reaching the instrument.

WGI pigtail siphons are recommended for services involving temperatures above 60°C/140°F. On steam service, the siphon will prevent steam from entering a pressure gauge, diaphragm seal or transmitter. WGI pigtail siphons are available in carbon steel and 316 stainless steel.



Specifications

Sizes

1/4" and 1/2" NPT

Material

Carbon or 304/316 SS

Pressure Ratings

BS-1/2 3,000 PSI
 BS-1/4 3,000 PSI
 PS-1/4 2,000 PSI or 5,000 PSI
 PS-1/2 2,000 PSI or 5,000 PSI

Pigtail Siphon Optional Materials

Special materials include 304 SS, monel, tantalum, hastelloy B & C, carpenter 20, nickel and titanium

Pigtail Siphon Optional Styles

Single, double or triple loops

Temperature Rating

BS-1/2 700°F 3,000 PSI

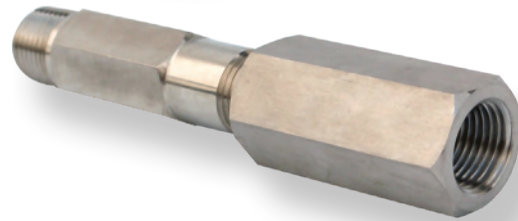

Barrel Siphon		
Part Number	Size	Material
BS-1/4	1/4" NPT male x female	316 SS
BS-1/2	1/2" NPT male x female	316 SS
Pigtail Siphon		
Part Number	Size	Material
PS-1/4	1/4" MNPT	Carbon Steel
PS-1/2	1/2" MNPT	Carbon Steel
PSS-1/4	1/4" MNPT	316 SS
PSS-1/2	1/2" MNPT	316 SS
Cooling Tower		
Part Number	Size	Material
CT-1/2	1/2" NPT	316 SS



WGI Master-Temp 200 / 300 Bimetal Thermometers



WGI bimetal thermometers are rugged and are preferred by the process, offshore, pharmaceutical, power and chemical industries. Liquid filling is available for additional dampening, extreme vibration, or to ensure consistent performance in low temperature or high humidity applications.

Specifications

Case Material	303 SS
Pointer	Black aluminum
Dial	Dished white aluminum with black lettering
Accuracy	± 1% full scale
Connection	1/4", 1/2" NPT Center back mount or - 1/2" adjustable angle
Window	Glass
Stem	1/4" O.D. 304 SS 2 1/2" - 36"
Dial Size	2" and 3"
External Reset	Stainless steel hex located on rear of case



Dial Size	2" Dial						
Connection	1/4" NPT Center Back Mount				1/2" NPT Center Back Mount		
Stem Length	2 1/2"	4"	6"	9"	2 1/2"	4"	6"
Ranges							
-40°F — 160°F (-40°C — 70°C)	WL11102	WL11202	WL11302	N/S	N/S	WL21202	WL21302
0°F — 250°F (-20°C — 120°C)	WL11105	WL11205	WL11305	N/S	N/S	N/S	WL21305
50°F — 500°F (10°C — 260°C)	WL11108	WL11208	WL11308	N/S	N/S	WL21208	N/S

Dial Size	3" Dial						
Connection	1/2" NPT Center Back Mount						
Stem Length	2 1/2"	4"	6"	9"	12"	15"	18"
Ranges							
-40°F — 160°F (-40°C — 70°C)	WL31102	WL31202	WL31302	WL31402	WL31502	WL31602	WL31702
0°F — 250°F (-20°C — 120°C)	WL31105	WL31205	WL31305	WL31405	WL31505	WL31605	WL31705
50°F — 300°F (10°C — 150°C)	WL31106	WL31206	WL31306	WL31406	WL31506	WL31606	WL31706
50°F — 500°F (10°C — 260°C)	WL31108	WL31208	WL31308	WL31408	WL31508	WL31608	WL31708
150° — 750°F (50°C — 400°C)	WL31110	WL31210	WL31310	WL31410	WL31510	WL31610	WL31710
200° — 1,000°F (100° — 550°C)	WL31111	WL31211	WL31311	WL31411	WL31511	WL31611	WL31711

Dial Size	3" Dial						
Connection	1/2" NPT Center Back Mount Adjustable Angle						
Stem Length	2 1/2"	4"	6"	9"	12"	15"	18"
Ranges							
-40°F — 160°F (-40°C — 70°C)	WL33102	WL33202	WL33302	WL33402	WL33502	WL33602	WL33702
0°F — 250°F (-20°C — 120°C)	WL33105	WL33205	WL33305	WL33405	WL33505	WL33605	WL33705
50°F — 300°F (10°C — 150°C)	WL33106	WL33206	WL33306	WL33406	WL33506	WL33606	WL33706
50°F — 500°F (10°C — 260°C)	WL33108	WL33208	WL33308	WL33408	WL33508	WL33608	WL33708
150°F — 750°F (50°C — 400°C)	WL33110	WL33210	WL33310	WL33410	WL33510	WL33610	WL33710
200°F — 1,000°F (100°C — 550°C)	WL33111	WL33211	WL33311	WL33411	WL33511	WL33611	WL33711

WGI Master-Temp 500 Bimetal Thermometers



WGI bimetal thermometers are rugged and are preferred by the process, offshore, pharmaceutical, power and chemical industries. Liquid filling is available for additional dampening, extreme vibration, or to ensure consistent performance in low temperature or high humidity applications.

Specifications

Case Material
303 SS

Dial
White aluminum black lettering

Pointer
Black aluminum

Dial
Dished white aluminum with black lettering

Accuracy
± 1% full scale

Connection
1/2" NPT Center back mount or
1/2" adjustable angle

Window
Glass

Stem
1/4" O.D. 304 SS 2 1/2" - 36"

Dial Size
5"

External Reset
Stainless steel hex located on rear of case



Dial Size	5" Dial						
Connection	1/2" NPT Center Back Mount						
Stem Length	2 1/2"	4"	6"	9"	12"	15"	18"
Ranges							
-40°F — 160°F (-40°C — 70°C)	WL51102	WL51202	WL51302	WL51402	WL51502	WL51602	WL51702
0°F — 250°F (-20°C — 120°C)	WL51105	WL51205	WL51305	WL51405	WL51505	WL51605	WL51705
50°F — 300°F (10°C — 150°C)	WL51106	WL51206	WL51306	WL51406	WL51506	WL51606	WL51706
50°F — 500°F (10°C — 260°C)	WL51108	WL51208	WL51308	WL51408	WL51508	WL51608	WL51708
150°F — 750°F (50°C — 400°C)	WL51110	WL51210	WL51310	WL51410	WL51510	WL51610	WL51710
200°F — 1,000°F (100°C — 550°C)	WL51111	WL51211	WL51311	WL51411	WL51511	WL51611	WL51711

Dial Size	5" Dial						
Connection	1/2" NPT Center Back Mount Adjustable Angle						
Stem Length	2 1/2"	4"	6"	9"	12"	15"	18"
Ranges							
-40°F — 160°F (-40°C — 70°C)	WL53102	WL53202	WL53302	WL53402	WL53502	WL53602	WL53702
0°F — 250°F (-20°C — 120°C)	WL53105	WL53205	WL53305	WL53405	WL53505	WL53605	WL53705
50°F — 300°F (10°C — 150°C)	WL53106	WL53206	WL53306	WL53406	WL53506	WL53606	WL53706
50°F — 500°F (10°C — 260°C)	WL53108	WL53208	WL53308	WL53408	WL53508	WL53608	WL53708
150°F — 750°F (50°C — 400°C)	WL53110	WL53210	WL53310	WL53410	WL53510	WL53610	WL53710
200°F — 1,000°F (100°C — 550°C)	WL53111	WL53211	WL53311	WL53411	WL53511	WL53611	WL53711

Continued...

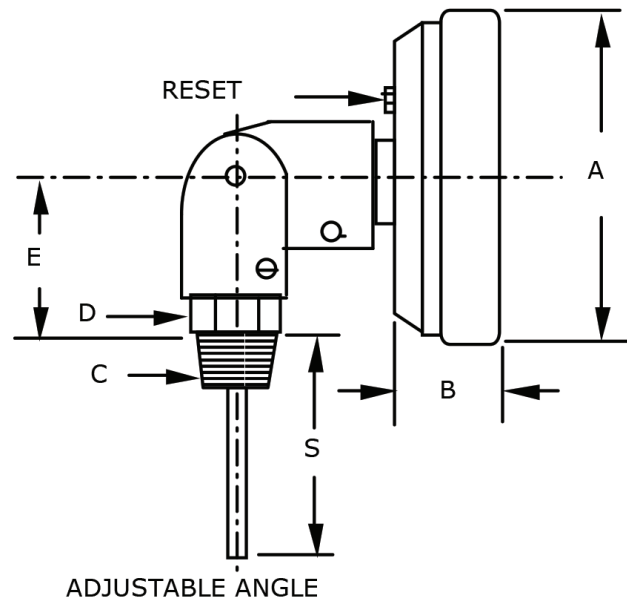
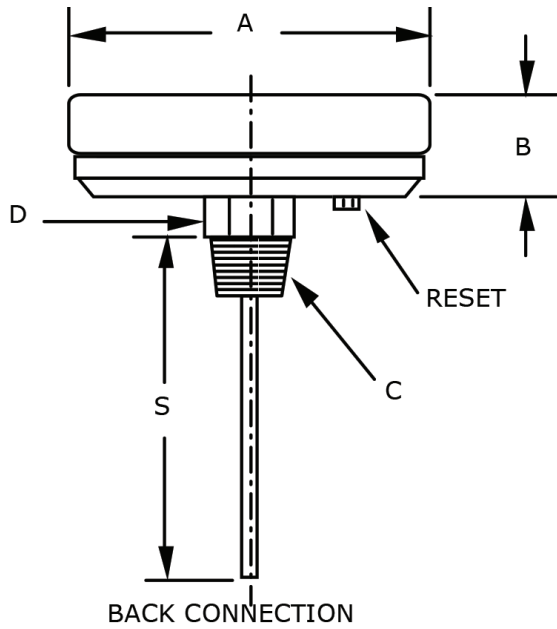

Ranges	Major Divisions		Minor Divisions	
	°F	°C	°F	°C
-40°F — 160°F (-40°C — 70°C)	10	10	2	2
0°F — 250°F (-20°C — 120°C)	10	10	2	2
50°F — 300°F (10°C — 150°C)	10	10	2	2
50°F — 500°F (10°C — 260°C)	25	10	5	5
150°F — 750°F (50°C — 400°C)	50	10	10	5
200°F — 1,000°F (100°C — 550°C)	50	10	10	5

Series	Dial Size	A	B	C
WL11000	2"	2.13"	0.425"	1/4" NPT
WL21000	2"	2.13"	0.425"	1/2" NPT
WL31000	3"	3.27"	0.835"	1/2" NPT
WL33000	3"	3.27"	0.835"	1/2" NPT
WL51000	5"	5.26"	0.910"	1/2" NPT
WL53000	5"	5.26"	0.910"	1/2" NPT

This device is used to protect a thermometer / thermocouple / RTD from any pressure or corrosion from the process and allows replacement of the instrument without shutting down the system.

Specifications

Standard Bore Sizes
0.260", 0.385" and 0.702"

Process Connections
NPT threaded or flanged (RF, FF and RTJ)

Standard Materials
316 SS

Optional Materials
Brass or naval brass, aluminum, carbon steel, chrome-moly, 304 SS, 316L alloy-20, inconel, monel, nickel, titanium, hastelloy B or C and teflon

Optional
Lagging extensions, stainless steel plug and chain, full penetration weld on flange, teflon or kynar coating, MTR test reports and hydrostatic internal testing

Available Stem Lengths
2½" — 36"

Process Connections
1/2", 3/4" and 1" threaded NPT, 150#, 300# and 600# flanged
900# RTJ and 150# RTJ



Stepped Thermowell

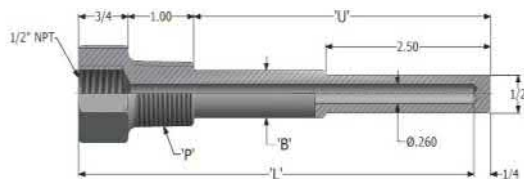

Straight Thermowell

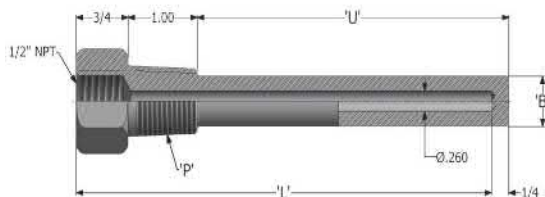

Tapered Thermowell

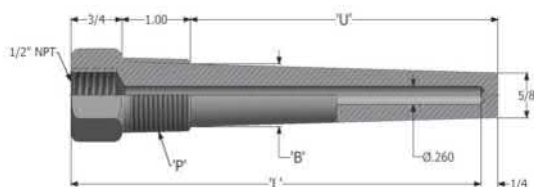

Continued....

Dimensions: inch

Process Connection	Part Number	Stem Length "L"	Insertion "U"	Bore Size	Overall Length
½" Male NPT	½-025-316	2 ½"	1 ⅜"	0.260	2 ¾"
	½-040-316	4"	2 ½"	0.260	4 ¼"
	½-060-316	6"	4 ½"	0.260	6 ¼"
	½-090-316	9"	7 ½"	0.260	9 ¼"
Process Connection	Part Number	Stem Length "L"	Insertion "U"	Bore Size	Overall Length
¾" Male NPT	¾-025-316	2 ½"	1 ⅜"	0.260	2 ¾"
	¾-025-316-385	2 ½"	1 ⅜"	0.385	2 ¾"
	¾-025-316-702	2 ½"	1 ⅜"	0.702	2 ¾"
	¾-035-316-702	2 ½"	2"	0.702	2 ¾"
	¾-040-316	4"	2 ½"	0.260	4 ¼"
	¾-040-316-385	4"	2 ½"	0.385	4 ¼"
	¾-040-316-702	4"	2 ½"	0.702	4 ¼"
	¾-045-316-702	4 ¼"	3"	0.702	4 ½"
	¾-050-316-702	5"	3 ½"	0.702	5 ¼"
	¾-060-316	6"	4 ½"	0.260	6 ¼"
	¾-060-316-385	6"	4 ½"	0.385	6 ¼"
	¾-060-316-702	6"	4 ½"	0.702	6 ¼"
	¾-090-316	9"	7 ½"	0.260	9 ¼"
	¾-120-316	12"	10 ½"	0.260	12 ¼"
Process Connection	Part Number	Stem Length "L"	Insertion "U"	Bore Size	Overall Length
1" Male NPT	1-025-316	2 ½"	1 ⅜"	0.260	2 ¾"
	1-025-316-702	2 ½"	1 ⅜"	0.702	2 ¾"
	1-035-316-702	2 ½"	2"	0.702	2 ¾"
	1-045-316-702	4 ¼"	3"	0.702	4 ½"
	1-040-316	4"	2 ½"	0.260	4 ¼"
	1-060-316	6"	4 ½"	0.260	6 ¼"
	1-090-316	9"	7 ½"	0.260	9 ¼"
	1-120-316	12"	10 ½"	0.260	12 ¼"

WGI 9" (229mm) Industrial Thermometer



WGI 9" (229mm) adjustable angle thermometer is mainly used for HVAC applications. Our standard case is a durable cast aluminum case powder coated dark blue and contains a safe red alcohol fill for easy viewing.

Specifications

Case Material
Die-cast blue V-shaped aluminum

Dial
White aluminum black lettering

Fill Fluid
Red reading alcohol for ranges up to 240°F/C, ranges above 240° F/C contain mercury as alcohol cannot exceed 300°F/C

Accuracy
± 1% full scale

Stem Length
3½" stem standard, optional 6½"

Connection
1¼" UNF brass jam nut

Window
Acrylic

Please Note: Thermowell Sold Separate

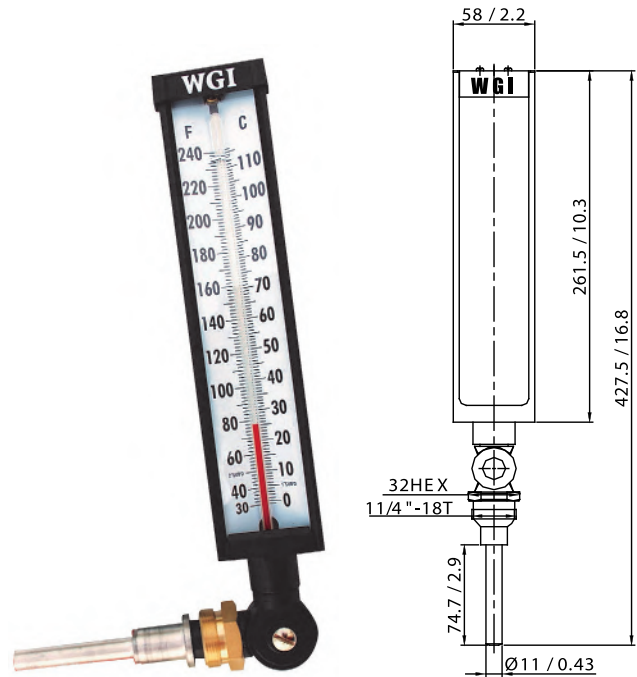

Part Number	Ranges	Stem Lengths
WAA3301	-40° — 110°F/C	3½"
WAA3303	0° — 120°F/C	3½"
WAA3304	0° — 180°F/C	3½"
WAA3305	30° — 240°F/C	3½"
WAA3308	50° — 550°F/C	3½"
WAA3601	-40° — 110°F/C	6"
WAA3603	0° — 120°F/C	6½"
WAA3604	0° — 180°F/C	6"
WAA3605	30° — 240°F/C	6"
WAA3608	50° — 550°F/C	6"

Thermowell - 1 ¼" (18 UNF)	Material	Stem Lengths
T1E3D2	Brass	3½"
T6E3D2	SS	3½"
T1E6D2	Brass	6"
T6E6D2	SS	6"

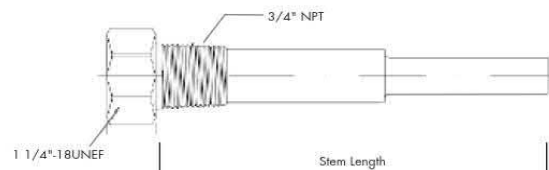

WGI 7" (177mm) Adjustable Angle Thermometer



WGI 7" (177mm) adjustable angle thermometer is mainly used in the HVAC industry but can also be used in many other industries. With an adjustable aluminum case and a standard 1/2" NPT brass thermowell, there are many applications for this thermometer. It also contains a red reading alcohol fill for easy viewing.

Specifications

Case Material
Die-cast aluminum

Dial
White aluminum black lettering

Fill Fluid
Red reading alcohol

Accuracy
± 1% full scale

Pointer
Black aluminum

Stem Length
2½" stem standard

Process Connection
Thermowell - 1/2" MNPT / C/W ½ NPT brass well

Window
Glass

NOTE: Thermowell Included

Part Number	Range
WAA2302	-40°F / 110°C
WAA2305	30°F / 240°C

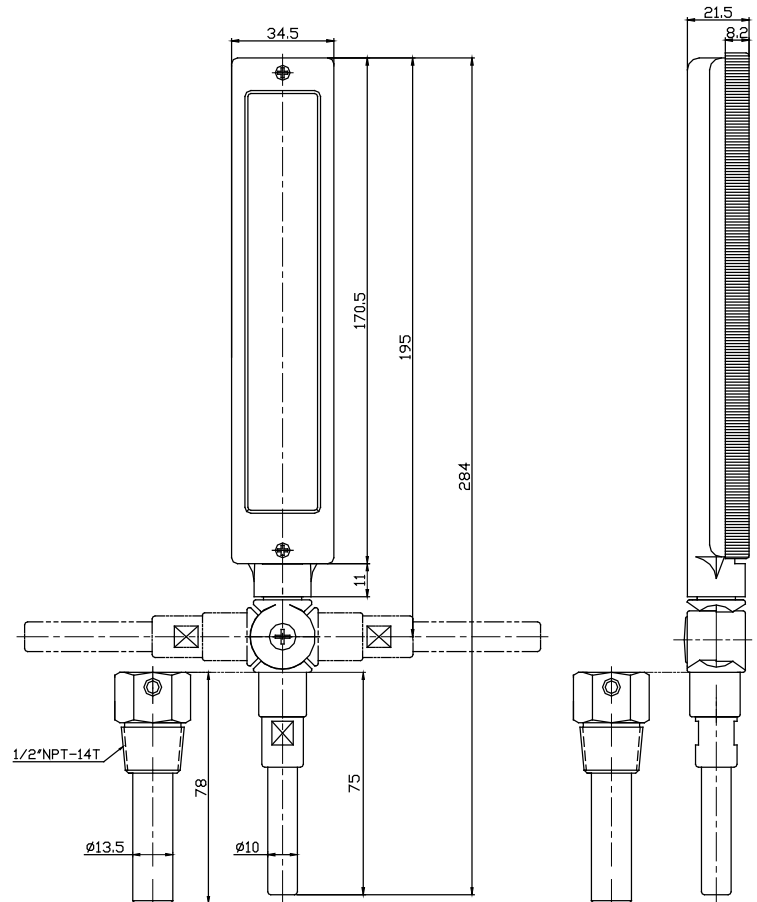

WGI Tridicators (Pressure / Temperature)



WGI tridicators indicate pressure, temperature and altitude in one compact instrument. WGI tridicators are intended for use on all types of hot water heating systems.

Specifications

Case Material
Drawn steel

Tube & Socket
Bronze tube, brass socket

Pointer
Black and red aluminum

Dial
White aluminum with black lettering

Accuracy
± 1% full scale

Connection
1/2" NPT

Window
Glass

Dial Size
3 1/2"

Dial Scale
Triple scale PSI, feet of water and degrees Celsius and Fahrenheit

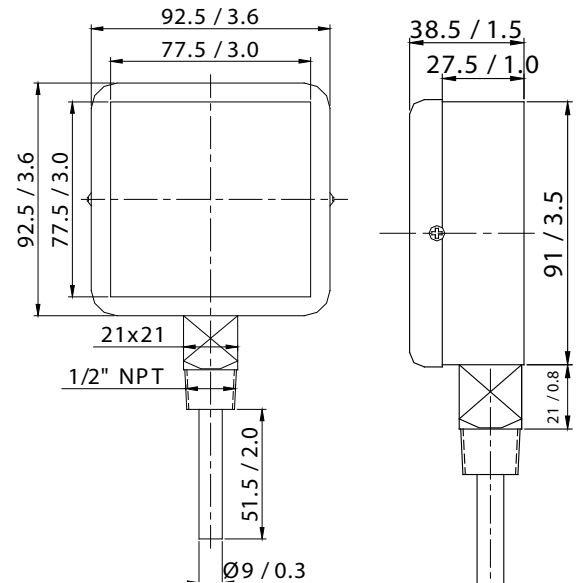
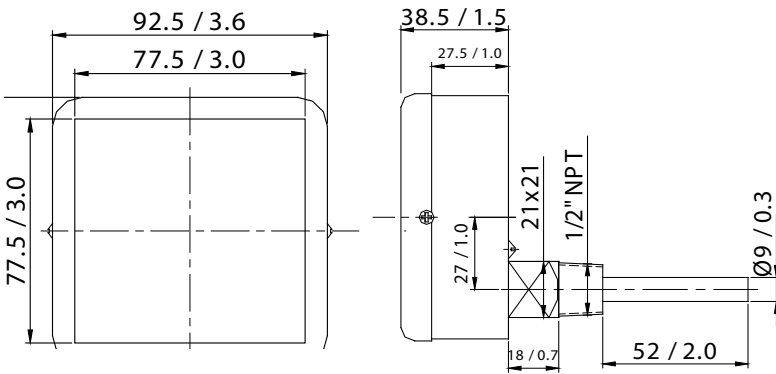

2 1/2" stem

Part Number	Connection	Temp Range	Pressure Range
Y22002	Bottom	30° — 260° F/C	0-60 PSI / kPa
Y22004	Bottom	30° — 260° F/C	0-100 PSI / kPa
Y22006	Lower Back	30° — 260° F/C	0-60 PSI / kPa
Y22008	Lower Back	30° — 260° F/C	0-100 PSI / kPa

6" stem

Part Number	Connection	Temp Range	Pressure Range
Y26002	Bottom	30° — 260° F/C	0-60 PSI / kPa
Y26006	Lower Back	30° — 260° F/C	0-60 PSI / kPa

WGI Tridicators (Pressure / Temperature)



WGI tridicators measure both pressure and temperature all in one instrument. They typically are used in HVAC or boiler applications.

Specifications

Case

Steel, black powder coated

Tube & Socket Stem

Bronze tube and brass socket

Pointer

Black powder coated aluminum

Dial

White Background with black lettering

Lens

Clear plastic

Dial Size

2½" dial

Range

Pressure: 0 - 100 PSI / kPa

Temperature: 60° — 260° F/C

Accuracy

3-2-3% Pressure + or - 1° C temperature

Connection

¼" male NPT, ¼" O.D. stem



Dimensions: mm / inch

Part Number	A	B	C
TRI-100	2.77	4.158	0.31
TRI-200	2.77	4.842	1.25
TRI-300	2.77	5.722	2.5

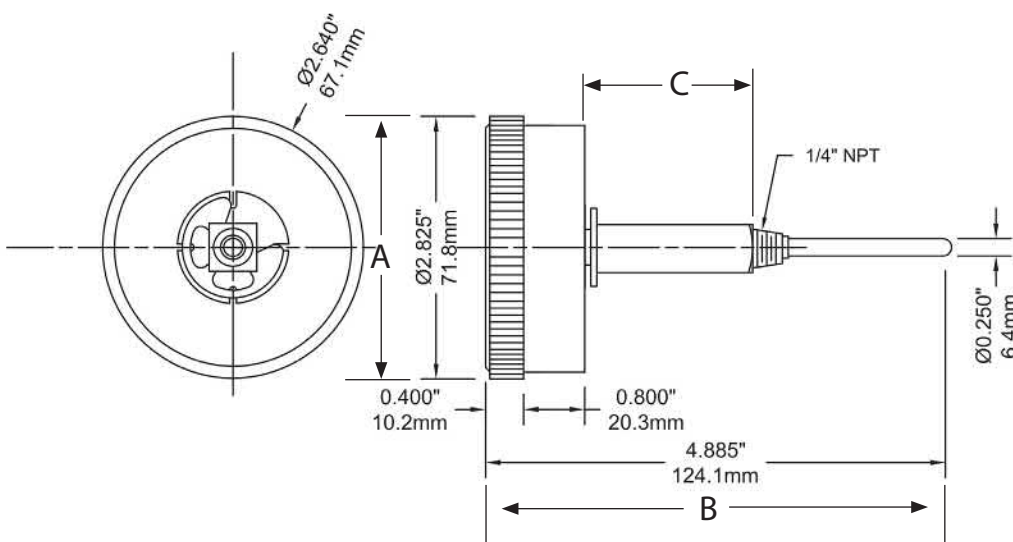

WGI tridicators measure both pressure and temperature all in one instrument. They typically are used in HVAC or boiler applications.

Specifications

Case
Steel, black powder coated

Tube & Socket Stem
Bronze tube and brass socket

Pointer
Black powder coated aluminum

Dial
White background with black lettering

Lens
Clear plastic

Dial Size
3" dial

Range
Pressure: 0 - 200 PSI / kPa
Temperature: 70° — 320° F/C

Accuracy
3-2-3% Pressure + or - 1°C temperature

Connection
1/2" male N.P.T., 1/4" O.D. stem

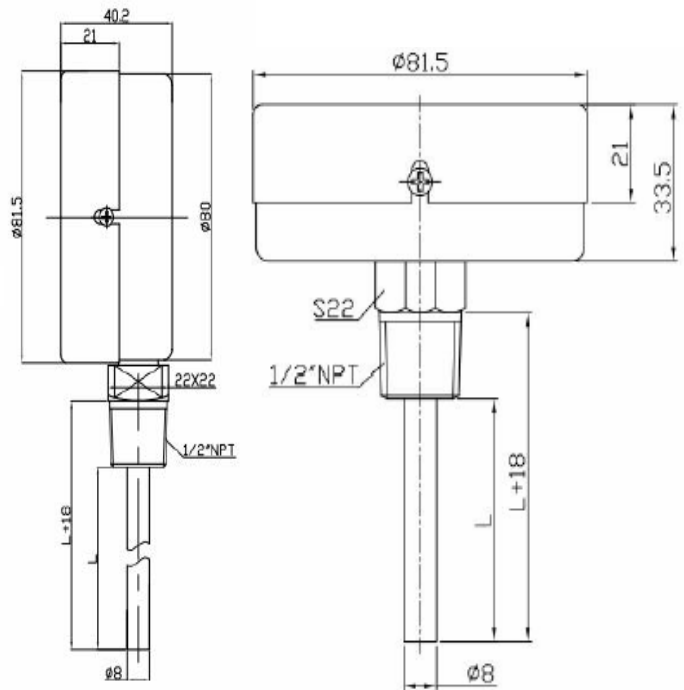

2 1/2" stem

Part Number	Connection	Temp Range	Pressure Range
Y32003	Bottom	70° — 320° F/C	0-75 PSI / kPa
Y32004	Bottom	70° — 320° F/C	0-100 PSI / kPa
Y32006	Bottom	70° — 320° F/C	0-200 PSI / kPa
Y34003	Back	70° — 320° F/C	0-75 PSI / kPa
Y34004	Back	70° — 320° F/C	0-100 PSI / kPa
Y34006	Back	70° — 320° F/C	0-200 PSI / kPa

TY4

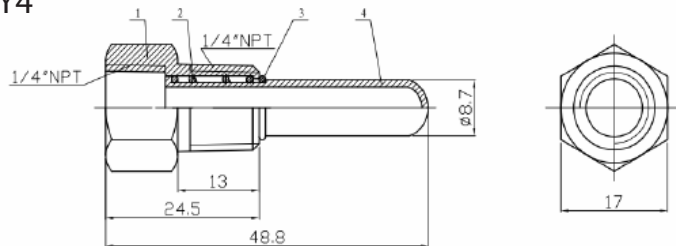

TY8

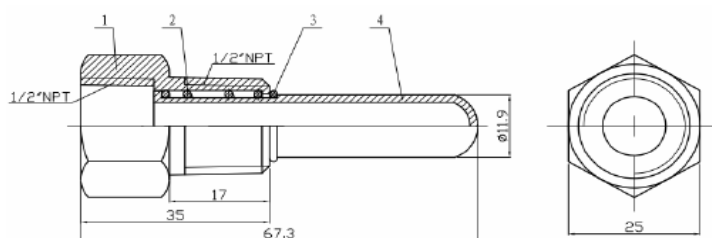

9841 Digital Pocket Thermometer

Specifications

Range

-40°F — 500°F (-40°C — 260°C)

Stem

5" Pointed SS

Dial Size

LCD Readout 0.3"

Accuracy

± 2°F or 1°C

Part Number	Temperature Range
9841	-40° — 500° F/C



General Purpose Pocket Thermometer Bi-metal Pocket Test Thermometer

Specifications

Dial Size

1 3/8" Dial

Stem

5" Pointed stainless steel

Recalibration

External recalibration screw on rear of case

Accuracy

± 2% Full Scale

Lens

Clear acrylic

Part Number	Temperature Range
PT1835-160FC	-40° — 160° F/C
PT1835-250FC	0° — 250° F/C
PT1835-500FC	50° — 500° F/C

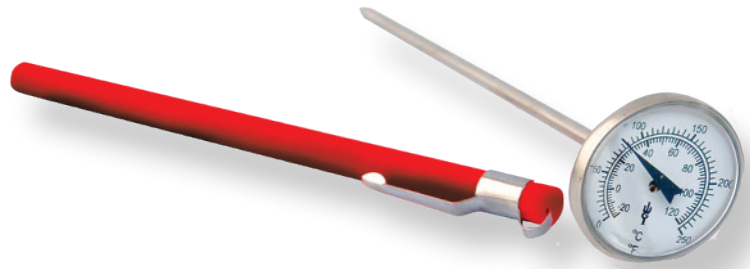

Glass Alcohol Pocket Thermometer GT-120 Pocket Test Thermometer

Specifications

Range

-58°F — 302°F (-50°C — 150°C)

Stem

Glass

Scale Size

5" Scale

Accuracy

± 2° F or 1° C

Part Number	Temperature Range
GT-120	-40°C — 120°C

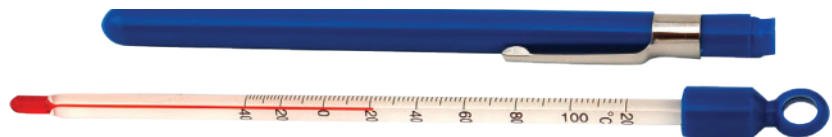

WGI Hot Water Heating Thermometer - Dial

WGI hot water thermometers are typically used in hot water heating systems, boilers and hydronic heating systems, etc. Each thermometer comes standard with a removable brass thermowell for maintaining a sealed system coupled with a rear recalibration screw.

Specifications

Case
Polished aluminum

Range
30° — 250° F/C

Connection
Comes with 1/2" NPT brass thermowell

Dial Size
2 1/2"

Accuracy
± 2°F or 1°C

Part Number	Temp Range
HWT2.5/250	30° — 250° F/C



WGI Hot Water Heating Thermometer - Scale

WGI hot water thermometers are typically used in hot water heating systems, boilers and hydronic heating systems, etc. Each thermometer comes standard with a removable brass thermowell for maintaining a sealed system.

Specifications

Case
Scale with steel case

Range
40°F — 280°F (5°C — 135°C)

Tube
Glass

Dial Size
8"

Accuracy
± 1°C/°F

Part Number	Pattern	Temp Range
HWT8-A	Angled	40° — 280° F/C
HWT8-S	Straight	40° — 280° F/C



WGI Magnetic Surface Thermometer

WGI bimetal magnetic surface thermometers incorporate a standard rear calibration adjustment and are ideal for use on engines, bearings, pipes, tanks, ovens, dies, molds or any flat metallic surface.

Specifications

Dial Size
2"

Lens
Clear acrylic

Case
Black aluminum

Mounting
Two magnets on rear of case

Accuracy
± 2% full scale



Part Number	Temp Range
311FC	-100° — 160° F/C
312FC	0° — 250° F/C
313FC	50° — 500° F/C

WGI Clamp-on Thermometer

WGI bimetallic clamp on thermometers are used to provide surface temperature on 1/2" to 4" pipes using a clamp-on design with steel spring. Ideal for HVAC, waste water and other industrial process applications.

Specifications

Dial Size
2 1/2"

Lens
Plexi glass

Case
Black aluminum

Mounting
Steel spring

Accuracy
± 3% full scale



Part Number	Temp Range
SBT-2	30° — 250° F/C

Taylor 1441E Digital Min / Max Thermometer

This thermometer is designed to read the temperature from two different probes on 9'9" (3 Meter) cables. It records the minimum and maximum temperatures for the current 24 hour period and for six previous periods. The advanced microprocessor circuit allows the thermometer to collect temperature data while the display is turned off. This saves battery life and only operates the LCD display during the time it is needed to read the temperature and recall any min/max data.

TAYLOR

Specifications

Range
20°F — 120°F (-29°C — 50°C)

Case
Plastic

Display Type
LCD

Accuracy
± 1.8°F or 1°C

Part Number	Temp Range
1441E	20°F — 120°F



Taylor Infrared Thermometer

The ideal introduction to non-contact thermometers for technicians new to infrared. This unit features the popular single dot laser sighting system and the large temperature display provides current and maximum readings together while scanning, all in a conveniently sized hand-held tool with a protective boot for added durability.

Specifications

Temperature Range
-49°F / 752°F (-45°C / 400°C)

Accuracy
± 1.5% of reading or ± 2°C

Scales
Switchable degrees F or C

Emissivity
Preset at 0.95

Sighting
Laser sight

Ratio
6 : 1

Part Number	Description
9523	Laser sight, comes with soft carry case



JMS Southeast - Provides quality temperature measurement products that are NIST certified and traceable to ITS 90 and IPTS-68. Products include; miniature and industrial thermocouples, bayonet and plastic melt sensors, resistance temperature devices (RTD's), thermowells, protection tubes and coatings, thermocouple and RTD wire, transmitters, thermistors and specialty sensors designed to fit your needs.



Specifications

Base Metal Types
Type J, K, T, E and N

Noble Metal Types
Type R, S and B

Element Options
Standard and special limits of error, grounded, ungrounded or exposed junctions, single and multiple element construction, standard and high purity mgo insulation.

Lead Termination Options
Plugs, jacks, spade lugs and special connectors

Sheath Materials
304/310/316/446 SS, Inconel 600, Microbell and H-2300

Sheath Diameters
 $\frac{1}{16}$ " $\frac{1}{8}$ " $\frac{3}{16}$ " $\frac{1}{4}$ " or $\frac{3}{8}$ "

Mounting Options
Compression fitting, welded bushings, flanged, bayonet fittings and weld pads

Connection Heads
General purpose and explosion proof



JMS Southeast Products

- RTD'S / Thermocouples
- Wire
- Protection Tubes
- Thermowells
- General Purpose and Explosion Proof Heads
- Accessories

JMS Swifty Sensor Service

24 Hour service or less for you
Emergency needs – No Expediting Charge!

We stock many different sizes and configurations. Please phone for price and delivery.

WGI 201 Carbon Steel Ball Valves



WGI ball valves combine quality performance at an affordable price. Each valve carries approvals that will cover most valve applications. These valves are used in different industries for a variety of applications.

Specifications

Pressure Rating
1/4" — 2" 2,000 PSI

Porting
Full port

Temperature Rating
-40°F — 392°F (-40°C — 200°C)

Body Material
ASTM A216-WCB

Approvals
NACE MR-0175
CRN
* Seal Weld Ends

Features
Blowing-Out Proof Stem
Locking Handle
Tapped and Drilled Mounting Pad



Item	Parts	Material
1	Body	ASTM A216 - WCB
2	Cap	
3	Ball	ASTM A351-CF8M
4	Stem	ASTM A276-316
5	Gland Nut	AISI 304
6	Seat	PTFE / RTFE
7	Seal	PTFE
8	Packing	PTFE / RTFE
9	Thrust Washer	PTFE
10	Spring Washer	AISI 304
11	Nut	
12	Handle	Stainless Steel
13	Handle Sleeve	PVC
14	Locking Device	AISI 304

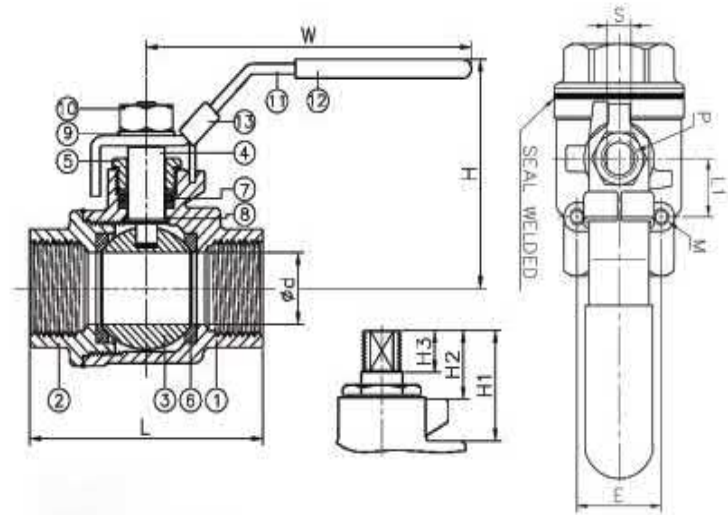

Thread type :
ASME B1.20.1 (NPT)
Dimensions: inch

NPS	D	L	L1	H	W	H1	H2	H3	S	M	E	T	Weight (lb)
1/4"	0.46	2.38	0.55	1.97	4.02	0.91	0.63	0.41	0.20	M5	1.10	5/16"W	0.6
3/8"	0.51	2.38	0.55	1.97	4.02	0.91	0.63	0.41	0.20	M5	1.10	5/16"W	0.6
1/2"	0.59	2.52	0.55	1.97	4.02	0.91	0.67	0.41	0.20	M5	1.10	5/16"W	0.7
3/4"	0.79	3.03	0.87	2.44	4.72	1.14	0.87	0.53	0.26	M5	1.38	3/8"W	1.2
1"	0.98	3.54	0.87	2.97	6.26	1.34	0.94	0.61	0.31	M5	1.38	7/16"W	1.9
1 1/4"	1.26	3.94	0.94	3.19	6.26	1.34	0.97	0.61	0.31	M5	1.54	7/16"W	2.8
1 1/2"	1.50	4.65	0.94	3.86	7.40	1.54	1.02	0.69	0.35	M5	1.5	1/2"W	4.4
2"	1.97	5.43	0.94	4.25	7.40	1.54	1.02	0.69	0.35	M5	1.5	1/2"W	6.9

WGI 301 CSA/CGA Stainless Steel Ball Valves



WGI ball valves combine quality performance at an affordable price. Each valve carries approvals that will cover most valve applications. These valves are used in different industries for a variety of applications.

Specifications

Pressure Rating
 1/4" — 1" 2,000 PSI
 1 1/4" — 2" 1,500 PSI

Porting
 Full Port

Temperature Rating
 -40°F — 392°F (-40°C — 200°C)

Body Material
 ASTM A351-CF8M

Approvals
 NACE
 CSA/CGA3.16 CRN

Features
 Blowing-Out Proof Stem
 Locking Handle
 Tapped and Drilled Mounting Pad



CSA / CGA 3.16 B16.33

Item	Parts	Material
1	Body	ASTM A351-CF8M
2	Cap	
3	Ball	ASTM A351-CF8M
4	Stem	ASTM A276-316
5	Gland Nut	AISI 304
6	Seat	PTFE / RTFE
7	Seal	PTFE
8	Packing	PTFE / RTFE
9	Thrust Washer	PTFE
10	Spring Washer	AISI 304
11	Nut	
12	Handle	PVC
13	Handle Sleeve	
14	Locking Device	AISI 304

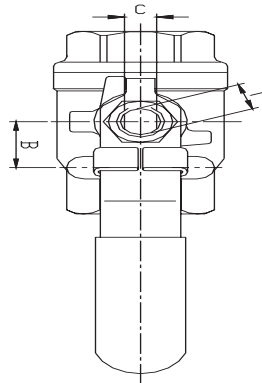
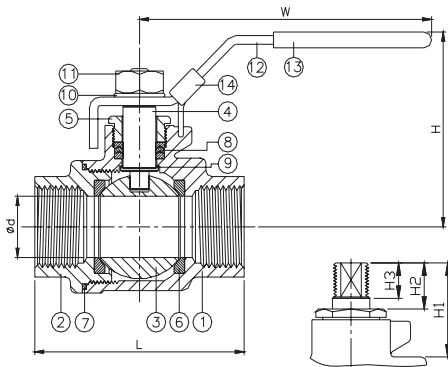

Dimensions: inch
 Thread type : ASME B1.20.1 (NPT)

NPS	D	L	L1	H	H1	H2	H3	W	S	E	M	T	Weight (lb)
1/4"	0.46	2.38	0.55	1.97	0.91	0.63	0.41	4.02	0.20	1.10	M5	5/16"W	0.60
3/8"	0.51	2.38	0.55	1.97	0.91	0.63	0.41	4.02	0.20	1.10	M5	5/16"W	0.60
1/2"	0.59	2.52	0.55	1.97	0.91	0.67	0.41	4.02	0.20	1.10	M5	5/16"W	0.70
3/4"	0.79	3.03	0.87	2.44	1.14	0.87	0.53	4.72	0.26	1.38	M5	3/8"W	1.20
1"	0.98	3.54	0.87	2.97	1.34	0.94	0.61	6.26	0.31	1.38	M5	7/16"W	1.90
1 1/4"	1.26	3.94	0.94	3.19	1.34	0.87	0.61	6.26	0.31	1.54	M5	7/16"W	2.80
1 1/2"	1.50	4.65	0.94	3.86	1.54	1.02	0.69	7.40	0.35	1.50	M5	1/2"W	4.40
2"	1.97	5.43	0.94	4.25	1.54	1.02	0.69	7.40	0.35	1.50	M5	1/2"W	6.90
2 1/2"	2.56	6.56	1.38	5.35	2.28	1.65	1.20	9.65	0.47	2.17	M5	3/4"W	13.20
3"	3.15	7.60	1.38	5.79	2.28	1.57	1.20	9.65	0.47	2.17	M5	3/4"W	22.30
4"	3.94	10.24	1.97	7.20	3.31	2.28	1.65	12.60	0.63	2.36	M5	1"W	-

WGI 401 Stainless Steel Ball Valves Seal Weld



WGI 401 series stainless steel ball valves carry 2,000 PSI rating for the larger sizes and have a seal welded body. This ensures that the body of the valve is sealed and will not leak after installation.

Specifications

Pressure Rating
1 1/4" — 2" 2,000 PSI

Porting
Full Port

Temperature Rating
-40°F — 392°F (-40°C — 200°C)

Body Material
ASTM A351-CF8M

Approvals
NACE MR-0175
CRN
* Seal Weld Ends

Features
Blowing-Out Pro of Stem
Locking Handle
Tapped and Drilled Mounting Pad

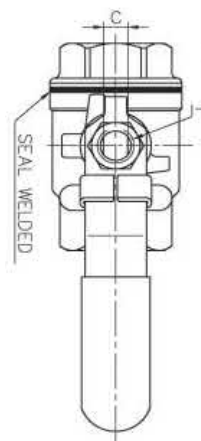
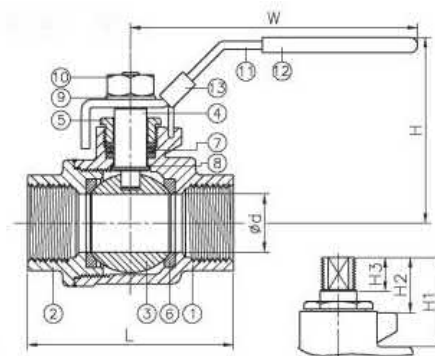

Item	Parts	Material
1	Body	ASTM A351-CF8M
2	Cap	ASTM A351-CF8M
3	Ball	ASTM A351-CF8M
4	Stem	ASTM A276-316
5	Gland Nut	AISI 304
6	Seat	PTFE / RTFE
7	Packing	Graphite
8	Thrust Washer	CTFE
9	Spring Washer	AISI 304
10	Nut	AISI 304
11	Handle	Stainless Steel
12	Handle Sleeve	PVC
13	Locking Device	AISI 304

Dimensions: inch

Thread type : ASME B1.20.1 (NPT)

NPS	d	L	W	H	H1	H2	H3	T	Weight (lbs)
1 1/4"	1.26	3.94	6.26	3.19	1.34	0.87	0.61	7/16"W	2.80
1 1/2"	1.5	4.65	7.4	3.86	1.54	1.02	0.69	1/2"W	4.40
2"	1.97	5.43	7.4	4.25	1.54	1.02	0.69	1/2"W	6.90

WGI 501 Stainless Steel Ball Valves



WGI ball valves combine quality performance at an affordable price. Each valve carries approvals that will cover most valve applications. These valves are used in many different industries for a variety of applications.

Specifications

Pressure Rating
1/4" — 2" 1,000 PSI

Porting
Full Port

Temperature Rating
-40°F — 392°F (-40°C — 200°C)

Body Material
ASTM A351-CF8M

Approvals
NACE
CRN

Features
Blowing-Out Pro of Stem
Locking Handle
Tapped and Drilled Mounting Pad



Item	Parts	Material
1	Body	ASTM A351-CF8M
2	Cap	ASTM A351-CF8M
3	Solid Ball	ASTM A351-CF8M
	Hollow Ball	ASTM A240-316
4	Stem	ASTM A276-316
5	Gland	AISI 304
6	Ball Seat	RTFE
7	Body Seal	PTFE
8	Packing	
9	Thrust Washer	
10	Spring Washer	AISI 304
11	Nut	
12	Handle	Stainless Steel
13	Handle Sleeve	PVC
14	Lock Device	Stainless Steel

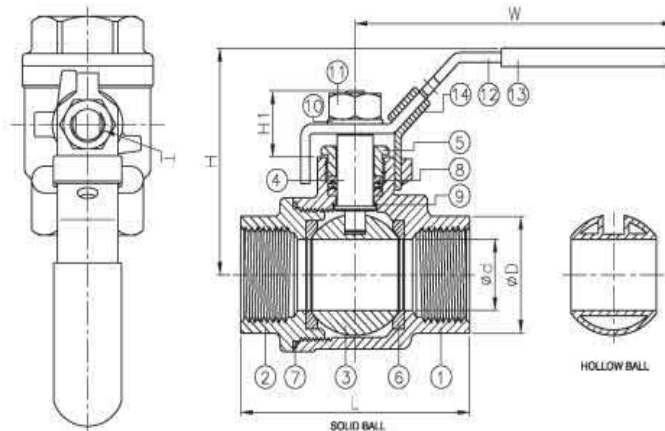

Dimensions: inch
Thread type : ASME B1.20.1 (NPT)

NPS	d	D	L	H	H1	T	W	S	Weight (lbs)	
									Solid Ball	Hollow Ball
1/4"	0.46	0.75	2.0	2.30	0.71	3/8" - 24UNF	3.94	0.35	0.5	-
3/8"	0.49	0.89	2.0	2.30	0.71	3/8" - 24UNF	3.94	0.35	0.5	-
1/2"	0.59	1.02	2.28	2.30	0.73	3/8" - 24UNF	3.94	0.35	0.7	-
3/4"	0.79	1.26	2.58	2.50	0.89	7/16" - 20UNF	4.92	0.35	1.0	-
1"	0.98	1.50	3.10	3.07	0.98	7/16" - 20UNF	5.87	0.43	1.7	-
1 1/4"	1.26	1.89	3.54	3.27	1.02	7/16" - 20UNF	5.87	0.43	2.5	-
1 1/2"	1.50	2.16	4.13	4.02	1.18	3/4" - 10UNF	7.48	0.55	3.9	-
2"	1.97	2.64	4.88	4.25	1.18	3/4" - 10UNF	7.48	0.55	5.9	5.2

WGI 601 Series Brass Ball Valves



WGI 601 series offers a high quality brass ball valve that is used in HVAC, agriculture, irrigation, hydraulic and other industries. This series complies with ANSI B1.20.1.

Specifications

Sizes

1/4" — 4" NPT

Porting

Full port

Body Material

Cast brass

Ball Material

Chrome plated brass

Seat Material

Teflon

Stem Packing

Teflon

Pressure Rating

600 PSI WOG / 150 PSI working steam pressure

Temperature Rating

-20°F — 300°F (-29°C — 150°C)

WOG Options

Optional solder by solder ends (special order)

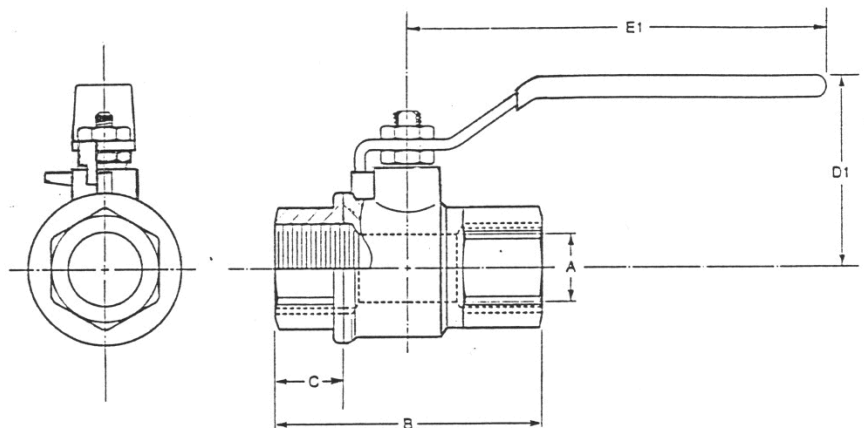

Dimensions: inch / mm

Part Number	A	B	C	D1	E1	Weight
601-1/4MF-MINI	0.22 / 5.6	1.75 / 44.5	0.375 / 10.0	1.75 / 44.5	1.5 / 88.9	0.44 / 88.9
601-1/4FF-MINI	0.22 / 5.6	1.75 / 44.5	0.375 / 10.0	1.75 / 44.5	1.5 / 88.9	0.44 / 88.9
601-1/4	0.25 / 6.4	1.75 / 44.5	0.375 / 10.0	1.75 / 44.5	3.50 / 88.9	0.44 / 88.9
601-3/8	0.375 / 9.5	1.75 / 44.5	0.375 / 10.0	1.75 / 44.5	3.50 / 88.9	0.44 / 88.9
601-1/2	0.50 / 12.7	2.00 / 50.8	0.50 / 12.7	1.95 / 49.5	3.50 / 88.9	0.55 / 0.25
601-3/4	0.75 / 19.1	2.25 / 57.2	0.57 / 14.5	2.10 / 53.3	4.10 / 104.1	0.77 / 0.35
601-1	1.00 / 25.4	2.80 / 71.1	0.70 / 17.0	2.60 / 66.0	4.70 / 119.4	1.28 / 0.58
601-1 1/4	1.25 / 31.8	3.22 / 81.8	0.75 / 19.1	3.00 / 76.2	4.70 / 119.4	2.20 / 1.00
601-1 1/2	1.50 / 38.1	3.60 / 91.4	0.75 / 19.1	3.35 / 85.1	5.75 / 146.1	3.04 / 1.38
601-2	2.00 / 50.1	4.20 / 106.7	0.80 / 20.3	3.60 / 91.4	5.75 / 146.1	3.86 / 1.75
601-2 1/2	2.50 / 63.5	5.30 / 134.6	1.00 / 25.4	4.50 / 114.3	9.20 / 233.7	8.27 / 3.75
601-3	3.00 / 76.2	6.25 / 158.8	1.20 / 30.5	4.90 / 124.5	9.20 / 233.7	11.02 / 5.00
601-4	4.00 / 101.6	7.40 / 188.0	1.40 / 35.6	5.70 / 144.8	9.20 / 233.7	18.19 / 8.25

WGI 701 / 702 Series Brass CSA Ball Valves NPT/Sold



Full port ball valves are manually operated ball valves for gas piping carrying natural gas, propane, butane, air and inert gases.

Specifications

Sizes

1/4" — 2"

Maximum Operating Pressure
600 WOG / 150 WSP

Body Material
Forged brass

Seats
PTFE

Stem Material
Forged brass

Handle
Steel

Packing
Double O-ring seal

Stem
Blow out proof

Temperature Limits
-30°F — 248°F (-30°C — 120°C)

Agency Approvals
CSA - FM - UL - CE

Thread Standard
ANSI B1.20.1

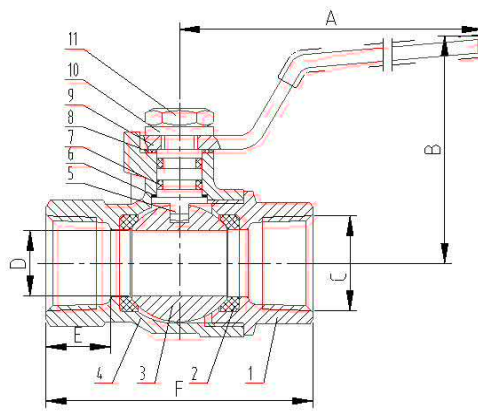

701 Threaded Series

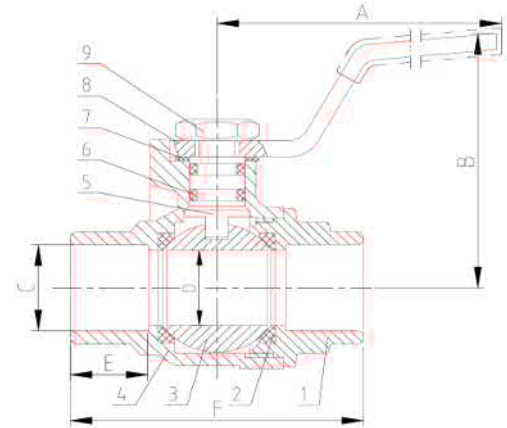

702 Solder Series

Threaded

Dimensions: mm / inch

Part Number	A	B	C	D	E	F
701-1/4	60	42	1/4 - 18 NPT	8	11.5	41.8
701-3/8	85	47	3/8 - 18 NPT	10	12.5	47.5
701-1/2	90	52	1/2 - 14 NPT	14	16	57.2
701-3/4	90	52.4	3/4 - 14 NPT	19	18.5	67.6
701-1	115	58.6	1 - 11 1/2 NPT	24	21	79.6
701-1 1/4	141	76	1 1/4 - 11 1/2 NPT	31	23	92.5
701-1 1/2	141	80	1 1/2 - 11 1/2 NPT	38	23.5	95.0
701-2	151	90	2 - 11 1/2 NPT	49	24	114.0

Solder

Part Number	A	B	C	D	E	F
702-1/2	90	50	16	14	12.5	52.6
702-3/4	95	54.5	22.3	19	19	74.0
702-1	115	62.7	28.7	24	23	90.0
702-1 1/4	140	73.5	35	31	24.5	99.0
702-1 1/2	140	75	41.4	38	28	113.5
702-2	150	86.5	54.1	49	34	133.0

CSA Certified

- For sizes 1/4" — 2"
- ANSI Z21.15/CSA 9.1
Class 3371-08 and Class 3371-88 0.5 PSI
- ANSI B16.33 Class 3371-14 and 3371-94 125 PSI
- CSA 3.16 Class 3371-10 125 PSI
- CSA 3-88 and CGA CR91-002 125 PSI
- ASME 16.44 Class 3371-92 5 PSI
- CSA file # 205653

WGI BKH /BK3 Series High Pressure Ball Valves

WGI BKH high pressure series ball valves are made of nickel plated carbon steel and are primarily used in the hydraulic industry where pressures operate around 5,000 PSI. WGI BKH series ball valves are field repairable, have blowout proof stems and delrin ball seats.

Specifications

Sizes
1/4" — 2" NPT

Porting
Full port

Body Material
Carbon steel

Ball and Stem Material
Nickel plated carbon steel

Seat Material
Delrin

Stem Packing
Buna N

Pressure Rating
1/4", 3/8" and 1/2" 7,350 PSI
3/4" — 2" 5,000 PSI

Temperature Rating
-20°F — 300°F (-29°C — 150°C)

Handle
Die-cast zinc

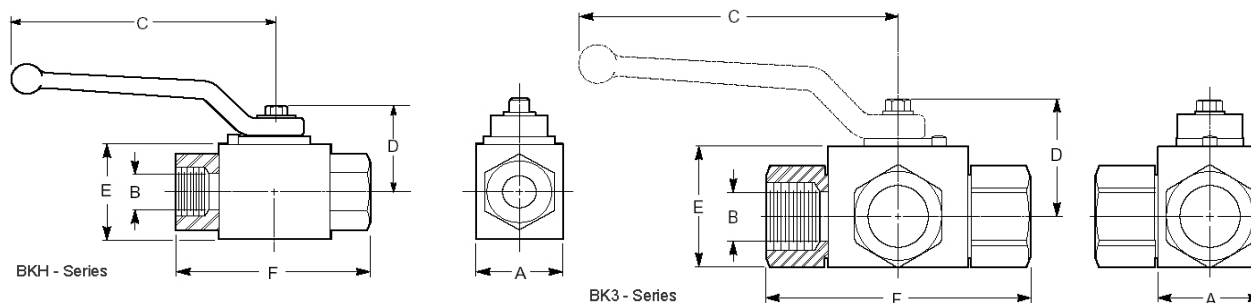
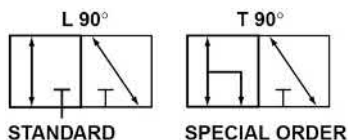

Dimensions & Part Numbers

Dimensions: mm

Part Number	Working Pressure	A	B	C	D	E	F	Weight KG
BKH-1/4	7,350 PSI	26	6	115	13.5	47	69	0.4
BKH-3/8	7,350 PSI	32	10	115	17.5	52	78	0.55
BKH-1/2	7,350 PSI	35	13	115	19	54	104	0.75
BKH-3/4	5,880 PSI	49	20	200	24.5	75	102	1.63
BKH-1	5,145 PSI	58	25	200	29.5	83	119	2.3
BKH-1 1/4	5,145 PSI	81	32	320	40.5	107	120	3.3
BKH-1 1/2	5,145 PSI	100	38	320	50	124	130	5.4

Dimensions & Part Numbers

Dimensions: mm

Part Number	Working Pressure	A	B	C	D	E	F
BK3-1/2	5,145 PSI	1.38	0.51	4.21	1.31	1.57	3.62
BK3-3/4	5,145 PSI	1.93	0.79	6.5	1.91	2.24	3.82
BK3-1	5,145 PSI	2.36	0.94	6.5	1.95	2.36	4.45

WGI Soft Seat In-line Check Valves



Soft seat high pressure in-line check valves are an ideal choice for preventing back-flow on any process system.

Specifications

Maximum Working Pressure
3,675 PSI — 10,000 PSI

Cracking Pressure
7 PSI (70 PSI optional)

Poppet "O" Rings
Carbon Steel - Buna N
Stainless Steel - Viton

Available
1/4" — 2"

Temperature Limits
Carbon -22°F — 212°F (-30°C — 100°C)
Stainless 13°F — 392°F (-25°C — 200°C)

Spring Material
Carbon Steel — 304 SS
Stainless Steel — 304 SS



Dimensions & Part Numbers

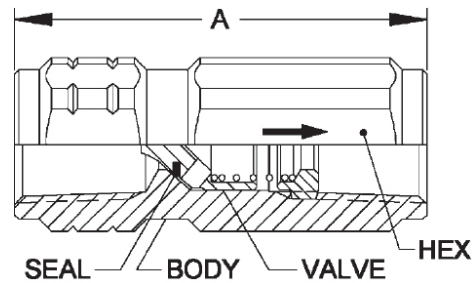
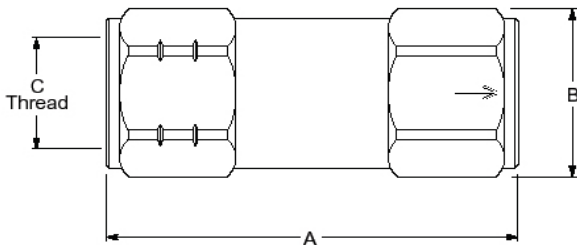

Size (inch)	Part No.	Thread NPTF	Dimensions		*Rated Pressure	
			A	Hex	PSI	BAR
1/4	VU-14-F-7	1/4-18	1.36	0.56	10,150	700
3/8	VU-38-F-7	3/8-18	1.80	0.88	10,150	700
1/2	VU-12-F-7	1/2-14	2.23	1.13	7,250	500
3/4	VU-34-F-7	3/4-14	1.80	0.88	7,250	500
1	VU-1-F-7	1-11 1/2	2.23	1.13	7,250	500

*Pressure ratings are given for valves in an open position with a constant flow.

Dimensions: inch

Part No.	Nominal Size	Working Pressure	Thread (C)	Cracking Pressure	Rated Flow	A	B (HEX)	Material
VU-14-F-7	1/4"	10,000 PSI	1/4" FNPT	7 PSI	5.8 GPM	1.97	0.75	CS
VU-14-F-7-SS	1/4"	5,145 PSI	1/4" FNPT	7 PSI	4.7 GPM	1.97	0.75	316 SS
VU-38-F-7	3/8"	10,000 PSI	3/8" FNPT	7 PSI	9.47 GPM	2.36	0.91	CS
VU-38-F-7-SS	3/8"	5,145 PSI	3/8" FNPT	7 PSI	10.5 GPM	2.37	0.95	316 SS
VU-12-F-7	1/2"	7,350 PSI	1/2" FNPT	7 PSI	17.9 GPM	2.76	1.06	CS
VU-12-F-7-SS	1/2"	5,145 PSI	1/2" FNPT	7 PSI	13.1 GPM	2.56	1.07	316 SS
VU-34-F-7	3/4"	7,350 PSI	3/4" FNPT	7 PSI	29.7 GPM	3.39	1.38	CS
VU-34-F-7-SS	3/4"	4,400 PSI	3/4" FNPT	7 PSI	23.7 GPM	2.96	1.34	316 SS
VU-1-F-7	1"	7,350 PSI	1" FNPT	7 PSI	35.8 GPM	3.94	1.62	CS
VU-1-F-7-SS	1"	3,675 PSI	1" FNPT	7 PSI	36.9 GPM	3.67	1.62	316 SS

WGI Hard Seat Needle Valves – Carbon Steel



This series of valves has been engineered for high flow and high pressure applications. Each valve has a large orifice for maximum flow at 10,000 PSI. Stem packing is adjustable and each bonnet has a bonnet lock pin.

Specifications

Sizes

1/8" — 1" NPT

Maximum Operating Pressure

10,000 PSI

Body & Bonnet Material

CS ASTM - A - 105N

Stem Material

ASME - SA - 479

Stem Packing

PTFE Teflon

Stem

Non-rotating tip for sizes 3/8" and above

Temperature Limits

-40°F — 500°F (-40°C — 260°C)

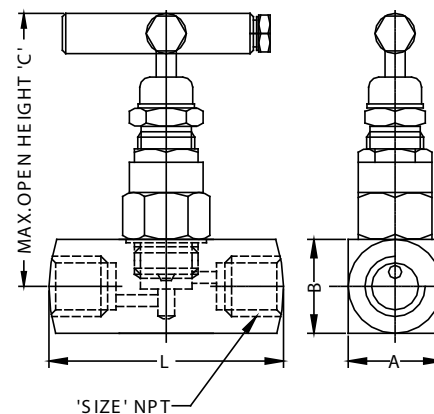
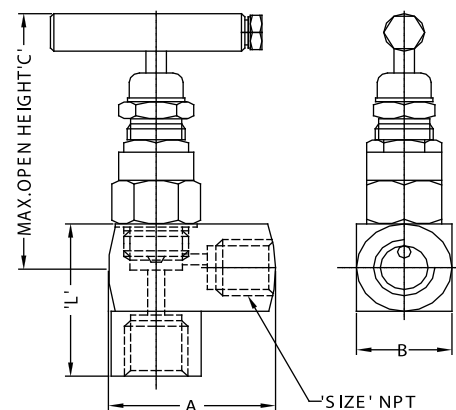
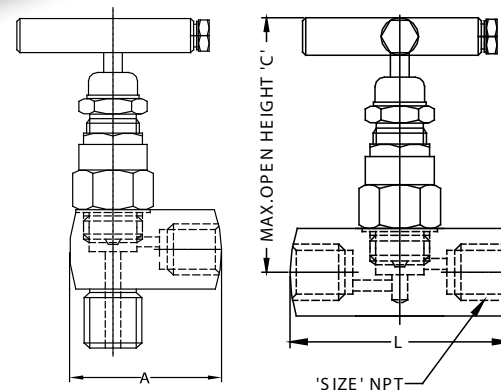

Dimensions: mm

Part Number	Size	Pattern	Ends	Material	A	B	C	L	L1	D	Cv
WN1511	1/8"	G	FxF	CS Nace	28.5	28.5	83	60	-	4.2	0.4
WN1512	1/4"	G	FxF	CS Nace	28.5	28.5	83	60	-	4.2	0.4
WN1513	3/8"	G	FxF	CS Nace	32	32	88	68	-	6.4	0.9
WN1514	1/2"	G	FxF	CS Nace	38	38	88	89	-	7	1.1
WN1516	3/4"	G	FxF	CS Nace	40	40	92	89	-	9	2.3
WN1518	1"	G	FxF	CS Nace	45	45	105	89	-	12	3.5
WN1532	1/4"	G	MxF	CS Nace	28.5	28.5	83	76	30	4.2	0.4
WN1533	3/8"	G	MxF	CS Nace	32	32	88	89	32	6.4	0.9
WN1534	1/2"	G	MxF	CS Nace	38	38	88	89	32	7	1.2
WN1536	3/4"	G	MxF	CS Nace	38	38	88	89	32	7	1.2
WN1537	3/4" x 1/2"	G	MxF	CS Nace	40	40	93	89	32	9	2.3
WN1538	1"	G	MxF	CS Nace	38	38	92	89	39	7	1.9
WN1551	1/8"	A	FxF	CS Nace	45	45	105	80	-	12	3.5
WN1552	1/4"	A	FxF	CS Nace	42	28	88	42	-	4.2	0.7
WN1553	3/8"	A	FxF	CS Nace	42	28	88	42	-	4.2	0.8
WN1554	1/2"	A	FxF	CS Nace	42	28	88	42	-	6.4	1.6
WN1556	3/4"	A	FxF	CS Nace	50	32	90	50	-	7	1.5
WN1558	1"	A	FxF	CS Nace	50	36	90	50	-	9	4.4
WN1572	1/4"	A	MxF	CS Nace	60	46	105	60	-	12	6.2
WN1574	1/2"	A	MxF	CS Nace	42	28	85	42	-	4.2	0.6

"D" : ORIFICE DIAMETER

WGI Hard Seat Needle Valves – Stainless Steel



This series of valves has been engineered for high flow and high pressure applications. Each valve has a large orifice for maximum flow at 10,000 PSI. Stem packing is adjustable and each bonnet has a bonnet lock pin. This series is made of 316 stainless steel for any corrosive applications.

Specifications

Sizes

1/8" — 1" NPT

Maximum Operating Pressure
10,000 PSI

Body & Bonnet Material
316 SS ASTM-A-479

Stem Material
316 SS ASTM-A-479

Stem Packing
PTFE Teflon

Stem
Non-rotating tip for sizes 3/8" and above

Temperature Limits
-40°F — 500°F (-40°C — 260°C)

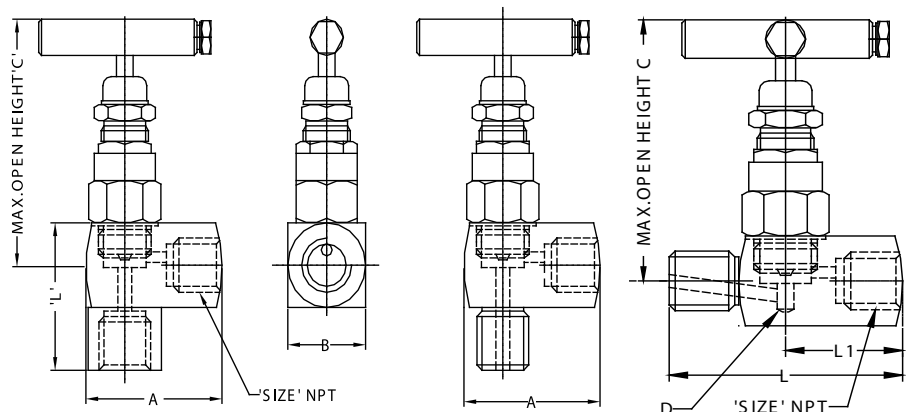

Dimensions: mm

Part Number	Size	Pattern	Ends	Material	A	B	C	L	L1	D	Cv
WN1311	1/8"	G	FxF	316 SS	28.5	28.5	83.0	60.0	-	4.2	0.40
WN1312	1/4"	G	FxF	316 SS	28.5	28.5	83.0	60.0	-	4.2	0.40
WN1313	3/8"	G	FxF	316 SS	32.0	32.0	88.0	68.0	-	6.4	0.90
WN1314	1/2"	G	FxF	316 SS	38.0	38.0	88.0	89.0	-	7.0	1.10
WN1316	3/4"	G	FxF	316 SS	40.0	40.0	92.0	89.0	-	9.0	2.30
WN1318	1"	G	FxF	316 SS	45.0	45.0	105.0	89.0	-	12.0	3.50
WN1332	1/4"	G	MxF	316 SS	28.5	28.5	83.0	76.0	30.0	4.2	0.40
WN1334	1/2"	G	MxF	316 SS	38.0	38.0	88.0	89.0	32.0	7.0	1.20
WN1336	3/4"	G	MxF	316 SS	38.0	38.0	88.0	89.0	32.0	7.0	1.20
WN1337	3/4" x 1/2"	G	MxF	316 SS	40.0	40.0	93.0	89.0	32.0	9.0	2.30
WN1338	1"	G	MxF	316 SS	38.0	38.0	92.0	89.0	39.0	7.0	1.90
WN1351	1/8"	A	FxF	316 SS	45.0	45.0	105.0	80.0	-	12.0	3.50
WN1352	1/4"	A	FxF	316 SS	42.0	28.0	88.0	42.0	-	4.2	0.70
WN1353	3/8"	A	FxF	316 SS	42.0	28.0	88.0	42.0	-	4.2	0.80
WN1354	1/2"	A	FxF	316 SS	42.0	28.0	88.0	42.0	-	6.4	1.60
WN1356	3/4"	A	FxF	316 SS	50.0	32.0	90.0	50.0	-	7.0	1.50
WN1358	1"	A	FxF	316 SS	50.0	36.0	90.0	50.0	-	9.0	4.40
WN1372	1/4"	A	MxF	316 SS	60.0	46.0	105.0	60.0	-	12.0	6.20
WN1374	1/2"	A	MxF	316 SS	42.0	28.0	85.0	42.0	-	4.2	0.60

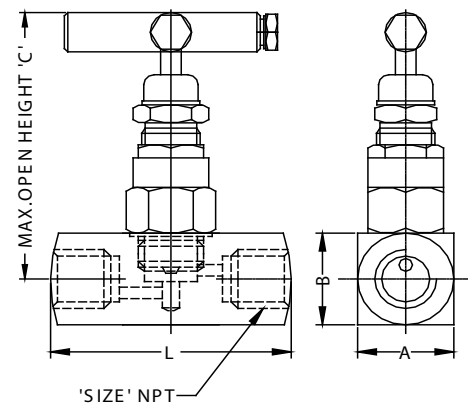

D= Orifice all dimensions in mm

WGI Soft Seat Needle Valves – Carbon / Stainless Steel



WGI soft seat needle valve series offers a bubble tight shut-off for critical applications. They also offer a great solution for applications requiring constant adjustments.

Specifications

Sizes

1/4" — 1" NPT

Maximum Operating Pressure
6,000 PSI

Body & Bonnet Material
CSASTM-A-105N
316 SS ASME-A-479

Stem Material
ASME - SA - 479

Stem Packing
PTFE Teflon

Stem
Non-rotating for sizes 3/8" and above

Temperature Limits
-40°F — 500°F (-40°C — 260°C)

Seat Material
Replaceable Delrin seat

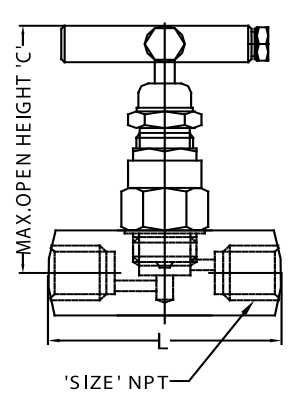
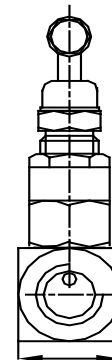
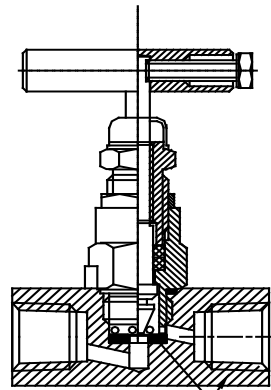
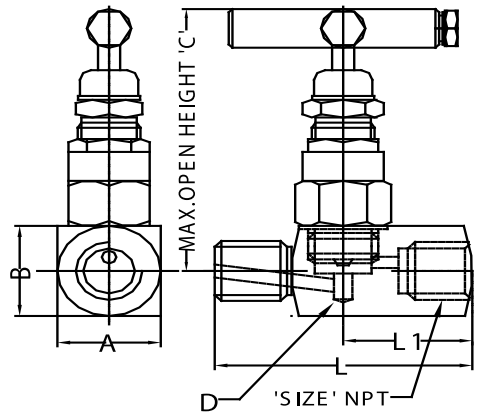

"SIZE" NPT
"B"
"SIZE" NPT
DRILL HOLES IN GLAND BODY PROVIDED TO PASS THE PROCESS TO OUTLET

Stainless Steel

Part Number	Size	Pattern	Ends	Material	A	B	C	L	L1	D
WN5312	1/4"	G	FxF	316 SS	28.5	28.5	83	60	-	4.2
WN5314	1/2"	G	FxF	316 SS	32.0	32.0	88	68	-	7.0
WN5316	3/4"	G	FxF	316 SS	40.0	40.0	92	68	-	9.0
WN5318	1"	G	FxF	316 SS	45.0	45.0	105	80	-	12.0
WN5332	1/4"	G	MxF	316 SS	28.5	28.5	83	76	32	4.2
WN5334	1/2"	G	MxF	316 SS	38.0	38.0	88	89	32	7.0
WN5336	3/4"	G	MxF	316 SS	38.0	38.0	92	89	32	7.0

Carbon Steel

Part Number	Size	Pattern	Ends	Material	A	B	C	L	L1	D
WN5512	1/4"	G	FxF	CS NACE	28.5	28.5	83	60	-	4.2
WN5514	1/2"	G	FxF	CS NACE	32	32	88	68	-	7
WN5516	3/4"	G	FxF	CS NACE	40	40	92	68	-	9
WN5518	1"	G	FxF	CS NACE	45	45	105	80	-	12
WN5532	1/4"	G	MxF	CS NACE	28.5	28.5	83	76	32	4.2
WN5534	1/2"	G	MxF	CS NACE	38	38	88	89	32	7
WN5536	3/4"	G	MxF	CS NACE	38	38	92	89	32	7

Dimensions: mm

WGI Multi Port Valves

WGI multi-port valve offers extra outlet ports to accommodate additional devices. They have a large orifice for extra flow and still workable to 10,000 PSI.

Specifications

Sizes

1/2" x 1/2", 3/4" x 1/2", 1" x 1/2"

Maximum Operating Pressure

10,000 PSI / 70,000 kPa / 700 bar

Body & Bonnet Material

CS-ASTM-A105N

316 SS ASTM-A479

Stem Material

ASME A-479

Handle

CS-ASTM - A105 and ASME - A-479

Dust Cap

Aluminum

Packing Material

PTFE Teflon, optional materials available.

Packing located below threads to insure clean smooth operation.

Stem

Non-rotating tip

Temperature Limits

Teflon -40°F — 500°F (-40°C — 250°C)

Traceability

Each valve has a number stamped on it tractable to a MTR. The hard copies are available upon request.

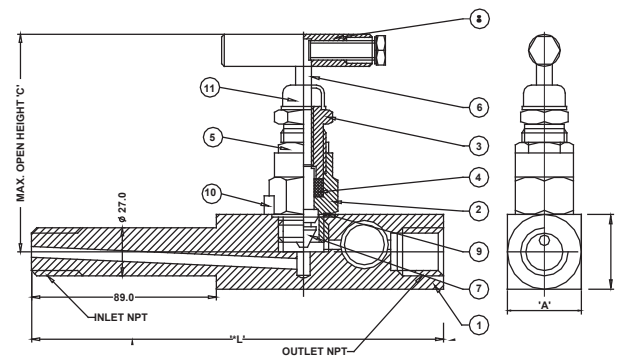
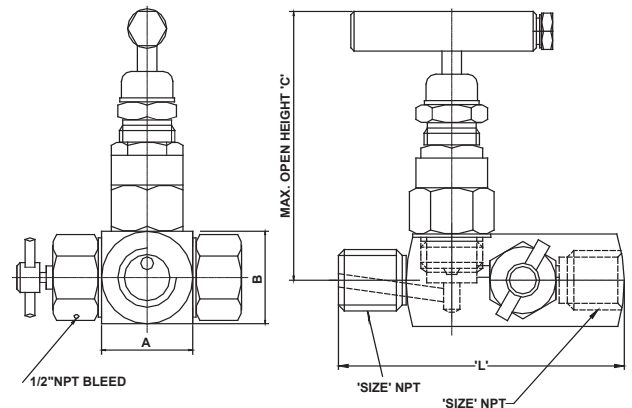
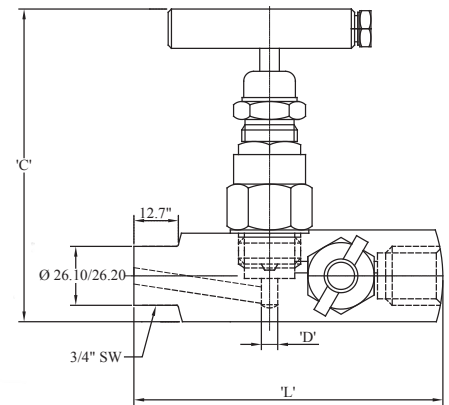

Dimensions: mm

No.	Part	WN75	WN85
1	Handle	CS	SS
2	Spindle	CS	SS
3	Dust Cap	Plastic	Plastic
4	Nut	CS	SS
5	Identification Ring	Aluminum	Aluminum
6	Gland	CS	SS
7	Body	CS	SS
8	Lock Pin	SS	SS
9	Packing	PTFE/Grafoil	PTFE/Grafoil

Part Number	Size	Pattern	Ends	Material	A	B	C	L	D
WN7534	1/2" x 1/2"	G	M X F	CS NACE	32.0	32.0	88.0	95.0	7.0
WN7536	3/4" x 1/2"	G	M X F	CS NACE	32.0	32.0	88.0	95.0	7.0
WN8534	1/2" x 1/2"	G	M X F	316 SS	32.0	32.0	88.0	95.0	7.0
WN8536	3/4" x 1/2"	G	M X F	316 SS	32.0	32.0	88.0	95.0	7.0
WN8534-1L	1/2" x 1/2"	G	M X F	316 SS	38.5	38.5	88.0	129.0	7.0
WN8536-1L	3/4" x 1/2"	G	M X F	316 SS	38.5	38.5	88.0	129.0	7.0
WN8536-3L	3/4" x 1/2"	G	M X F	316 SS	38.5	38.5	88.0	180.0	7.0
WN8538-1L	1" x 1/2"	G	M X F	316 SS	38.5	38.5	88.0	129.0	7.0

WGI block and bleed needle valves offer a single valve combining isolation and venting of process mediums. It features a large orifice for high flow application and eliminates the need for the extra tubing and fittings.

Specifications

Sizes
1/4" and 3/4" NPT

Body & Bonnet Material
CS-ASTM - A - 105N /
316 SS ASTM - A-479

Stem Material
ASTM-A-105

Stem Packing
PTFE Teflon
Optional material available

Stem
Non-rotating tip

Temperature Limits
-40°F — 500°F (-40°C — 260°C)

Maximum Operating Pressure
10,000 PSI / 70,000 KPA / 700 BAR

**WGI Block and Bleed Valves M X F -
Hard Seat**

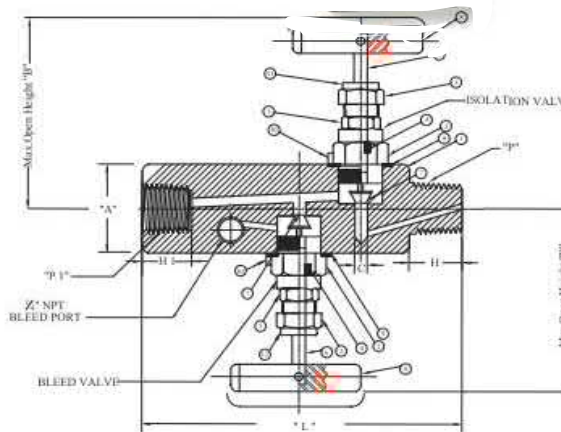

Dimensions: mm

Description	Qty.	Material
Body	1	CS-ASTM A 105/ 316 SS-ASTM A479
Gland Body	1	CS-ASTM A 105/ 316 SS-ASTM A479
Gland Retainer	1	CS-ASTM A 105/ 316 SS-ASTM A479
Gland Seal	1	PTFE / GRAFOIL
Lock Nut	1	CS-ASTM A 105/ 316 SS-ASTM A479
Spindle	1	316 SS-ASTM A479
Tip	1	316 SS-ASTM A479
Handle	1	CS-ASTM A 105/ 316 SS-ASTM A479
Washer	1	316 SS-ASTM A479
Lock Pin	1	Stainless Steel
Dust Cap	1	Aluminum

Part Number	Size NPT	Ends	Material	A	B	C	L	H	H1	CV
WN9732	1/4" X 1/4"	M X F	316 SS CS NACE	38.0	95.0	4.20	114.50	14.20	15.0	0.40
WN9734	1/2" X 1/2"	M X F	316 SS CS NACE	38.0	95.0	4.20	114.50	19.05	19.8	0.40
WN9736	3/4" X 1/2"	M X F	316 SS CS NACE	38.0	95.0	4.20	114.50	19.05	19.8	0.40
WN9532	1/4" X 1/4"	M X F	CS NACE	38.0	95.0	4.20	114.50	14.20	15.0	0.40
WN9534	1/2" X 1/2"	M X F	CS NACE	38.0	95.0	4.20	114.50	19.05	19.8	0.40
WN9536	3/4" X 1/2"	M X F	CS NACE	38.0	95.0	4.20	114.50	19.05	19.8	0.40

WGI Miniature Needle Valves - Hard Seat & Soft Seat



WGI miniseries offers a compact size with both hard and soft seat options. These valves are ideal for any application where size and price are important.

Specifications

Sizes

1/8" and 1/4" NPT

Maximum Operating Pressure
6,000 PSI

Body & Bonnet Material
ASTM - A - 105 / ASTM - A - 479

Stem Material
ASTM - A - 105

Stem Packing
PTFE Teflon

Stem
Rotating

Seat Material (WN06 & WN04 Series)
PTFE Teflon

Temperature Rating
-40°F — 500°F (-40°C — 260°C)

Max Operating Temperature
WN07/WN09 — 0-3,000 PSI
WN03, 04, 05, 06 — 0-6,000 PSI

WGI Miniature Needle Valves M X F - Hard Seat

No.	Description	QTY.	Material
1	Body	1	CS-ASTM A105/ 316 SS-ASTM A479
2	Gland Body	1	CS-ASTM A105/ 316 SS-ASTM A479
3	Gland Seal	1	PTFE/GRAFOIL
4	Hex Nut	1	CS-ASTM A105/ 316 SS-ASTM A479
5	Spindle	1	316 SS-ASTM A479
6	Tip	1	316 SS-ASTM A479
7	Handle	1	CS-ASTM A105/ 316 SS-ASTM A479
8	Washer	1	CS-ASTM A105/ 316 SS-ASTM A479
9	Lock Pin	1	CS-ASTM A105/ 316 SS-ASTM A479
10	Identification Ring	1	Aluminum

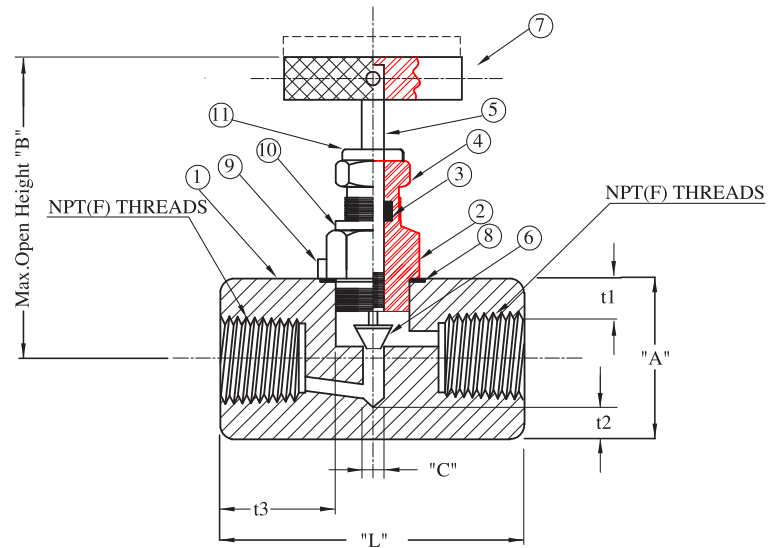

Dimensions: mm

Part Number	Size NPT	Ends	Material	A	B	C	L	t2	t3
WN0732	1/4" x 1/4"	M X F	316 SS	22.0	62.0	3.2	48.26	6.25	17.80
WN0932	1/4" x 1/4"	M X F	CS	22.0	62.0	3.2	48.26	6.25	17.80

WGI Miniature Needle Valves - Hard Seat - M x F

No.	Description	QTY.	Material
1	Body	1	CS ASTM A105/ 316 SS ASTM A479
2	Gland Body	1	CS ASTM A105/ 316 SS ASTM A479
3	Gland Seal	1	PTFE/Grafoil
4	Hex Nut	1	CS ASTM A105/ 316 SS ASTM A479
5	Spindle	1	316 SS ASTM A479
6	Tip	1	316 SS ASTM A479
7	Handle	1	CS ASTM A105/ 316 SS ASTM A479
8	Washer	1	CS ASTM A105/ 316 SS ASTM A479
9	Lock Pin	1	CS ASTM A105/ 316 SS ASTM A479
10	Identification Ring	1	Aluminum
11	Dust cap	1	Aluminum/Plastic

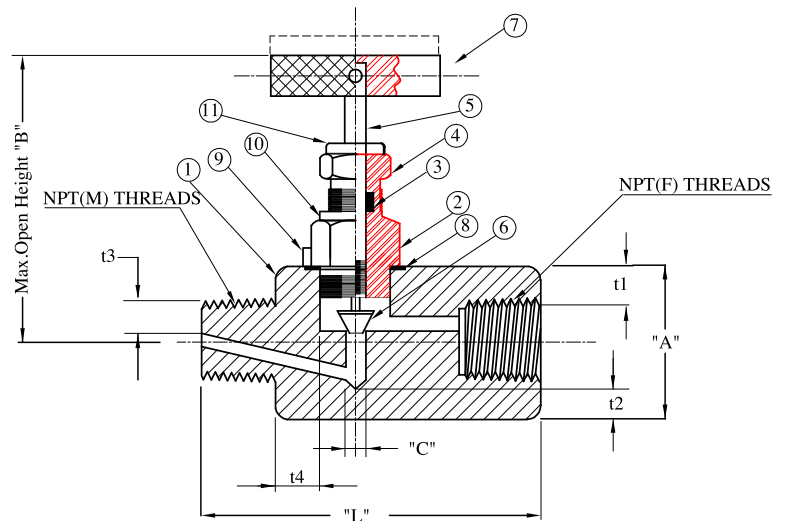

Dimensions: mm

Part Number	Size NPT	Ends	Material	A	B	C	L	t2	t1	t4
WN 0532	1/4" x 1/4"	M X F	CS	22.0	62.0	3.20	48.26	6.25	4.14	5.70
WN 0332	1/4" x 1/4"	M X F	316 SS	22.0	62.0	3.20	48.26	6.25	4.14	5.70

WGI Miniature Needle Valves - Soft Seat - F x F

No.	Description	QTY.	Material
1	Body	1	CS-ASTM A105/ 316 SS-ASTM A479
2	Gland Body	1	CS-ASTM A105/ 316 SS-ASTM A479
3	Spindle	1	316 SS-ASTM A479
4 (a)	Handle CS Valve	1	CS-ASTM A105
4 (b)	Handle 316 SS Valve	1	Aluminum
5	Lock Pin	1	ASTM A479
6	Soft Seat	1	DELTRIN

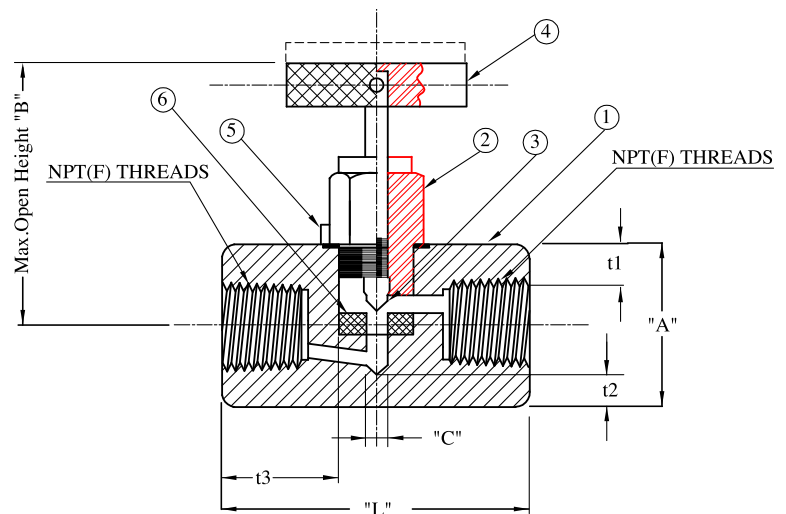

Dimensions: mm

Part Number	Size NPT	Ends	Material	A	B	C	L	t2	t1	t4
WN 0612	1/4" x 1/4"	F X F	CS	19.0	48.0	3.20	48.0	3.75	2.64	17.70
WN 0412	1/4" x 1/4"	F X F	316 SS	19.0	48.0	3.20	48.0	3.75	2.64	17.70

WGI Miniature Needle Valves - Soft Seat M x F

No.	Description	QTY.	Material
1	Body	1	CS-ASTM A105/ 316 SS-ASTM A479
2	Gland Body	1	CS-ASTM A105/ 316 SS-ASTM A479
3	Spindle	1	316 SS-ASTM A479
4(a)	Handle CS Valve	1	CS-ASTM A105
4(b)	Handle 316 SS Valve	1	Aluminum
5	Lock Pin	1	ASTM A479
6	Soft Seat	1	DELRIN

Pressure Rating: 6,000 PSI
Temperature Rating: 100°F

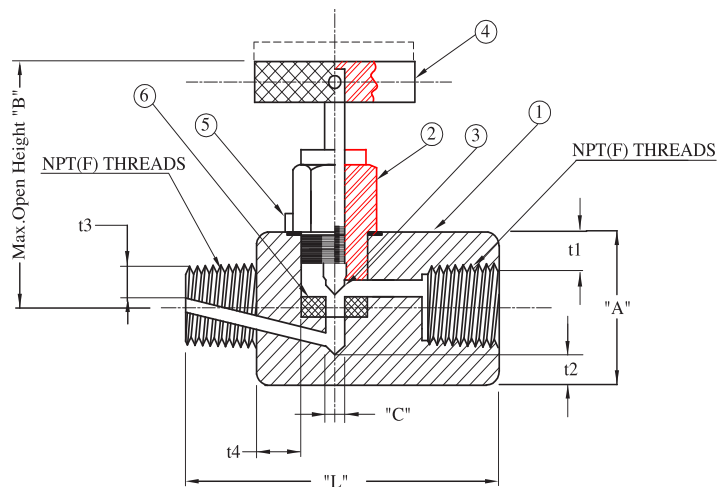

Part Number	Size NPT	Ends	Material	A	B	C	L	t2	t1	t3	t3
WN0632	1/4" X 1/4"	M X F	CS	19.0	48.0	3.20	48.0	3.75	2.64	3.90	5.70
WN0432	1/4" X 1/4"	M X F	316 SS	19.0	48.0	3.20	48.0	3.75	2.64	3.90	5.70

Brass Needle Valves

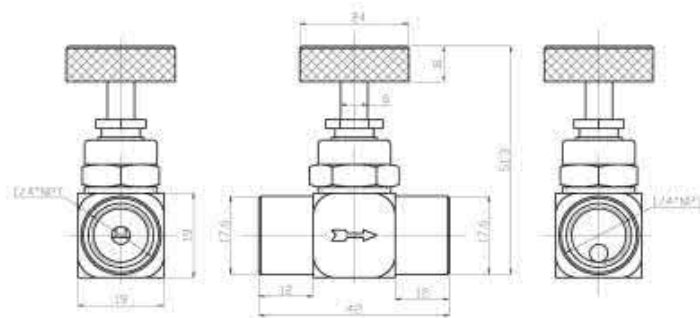

Part Number	Size	Material	Ends	Pressure & Temperature Rating
WN0112	1/4"	Brass	F x F	600 PSI, 300°F
WN0132	1/4"	Brass	M x F	600 PSI, 300°F

Carbon Steel

WGI packager series needle valve offers a compact valve at a very competitive price. The carbon steel valve comes with standard NACE MR0175 approval and carry a traceable heat number stamped on each valve.

Specifications

Sizes

1/4" — 1"

Maximum Operating Pressure

6,000 PSI tested at 10,000 PSI

Body & Bonnet Material

ASME - A175SN

Stem Material

ASME - SA - 479

Stem Packing

ASTM SA479

Stem

Non-rotating tip – 1/2" NPT and larger

Temperature Rating

-40°F — 500°F (-40°C — 260°C)

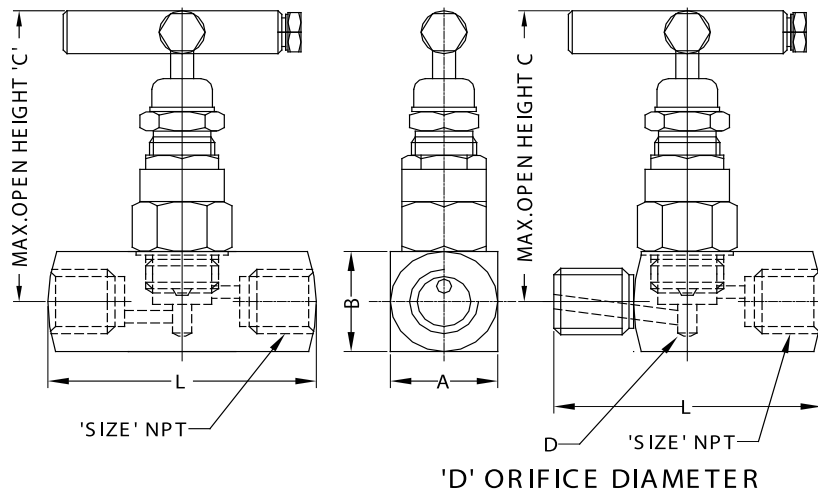

Dimensions: mm

Part Number	Size	Pattern	Ends	Material	CV	A	B	C	L	D
WN1612PN	1/4"	G	FxF	CS NACE	0.25	22.0	22.0	74	54.0	3.2
WN1613PN	3/8"	G	FXF	CS NACE	0.25	28.5	28.5	85	68.0	3.2
WN1614PN	1/2"	G	FxF	CS NACE	0.25	28.5	28.5	85	76.2	3.2
WN1616PN	3/4"	G	FXF	CS NACE	0.70	35.0	35.0	89	68.0	6.0
WN1618PN	1"	G	FXF	CS NACE	0.70	45.0	45.0	91	76.2	6.0
WN1631PN	1/2" x 3/8"	G	MXF	CS NACE	0.25	22.0	22.0	62	54.0	3.2
WN1632PN	1/4"	G	MxF	CS NACE	0.25	22.0	22.0	62	54.0	3.2
WN1633PN	3/8"	G	MXF	CS NACE	0.25	28.5	28.5	85	76.2	3.2
WN1634PN	1/2"	G	MxF	CS NACE	0.25	28.5	28.5	85	76.2	3.2
WN1635PN	1/2" x 1/4"	G	MXF	CS NACE	0.25	28.5	28.5	85	76.2	3.2
WN1636PN	3/4"	G	MXF	CS NACE	0.70	35.0	35.0	89	76.2	6.0
WN1637PN	3/4" x 1/2"	G	MxF	CS NACE	0.40	30.0	30.0	78	76.2	4.2
WN1638PN	1"	G	MXF	CS NACE	0.70	45.0	45.0	112	90.0	6.0
WN1639PN	1" x 1/2"	G	MXF	CS NACE	-	45.0	45.0	112	90.0	9.0

Stainless Steel

WGI stainless steel packager series offers all the same features as the carbon steel series but gives you the extra protection for any outdoor or extreme applications.

Specifications

Sizes
1/4" — 1"

Maximum Operating Pressure
6,000 PSI tested at 10,000 PSI

Body & Bonnet Material
ASME - SA - 479

Stem Material
ASME - SA-479

Stem Packing
PTFE Teflon

Stem
Non-rotating tip - 1/2" NPT and larger

Temperature Rating
-40°F — 500°F (-40°C — 260°C)

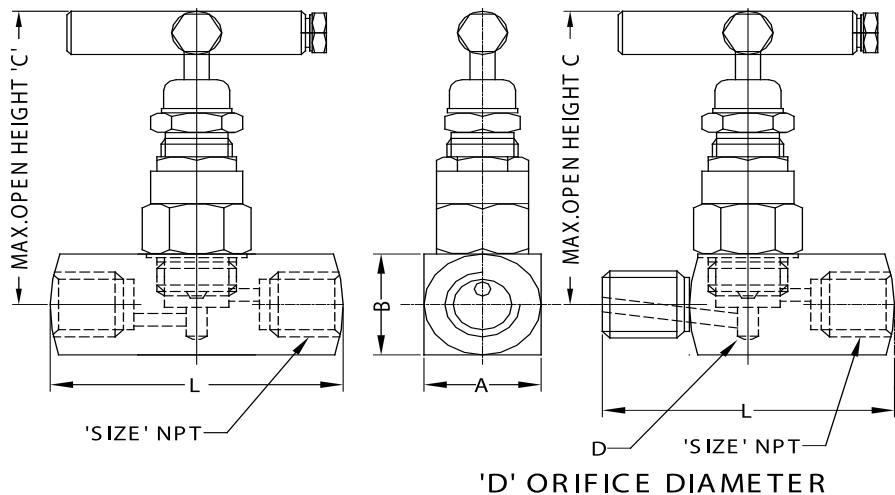
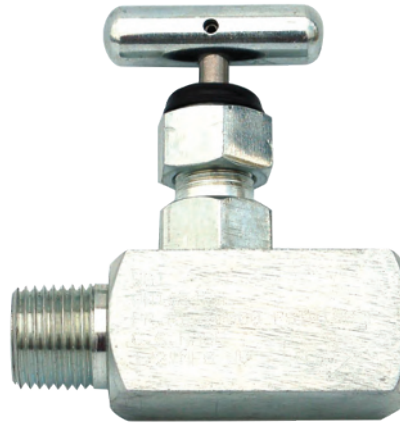

Dimensions: mm

Part Number	Size	Pattern	Ends	Material	CV	A	B	C	L	D
WN1412P	1/4"	G	FxF	316 SS	0.25	22.0	22.0	74	54.0	3.2
WN1413P	3/8"	G	FXF	316 SS	0.25	28.5	28.5	85	68.0	3.2
WN1414P	1/2"	G	FxF	316 SS	0.25	28.5	28.5	85	76.2	3.2
WN1416P	3/4"	G	FXF	316 SS	0.70	35.0	35.0	89	68.0	6.0
WN1418P	1"	G	FXF	316 SS	0.70	45.0	45.0	91	76.2	6.0
WN1431P	1/2" x 3/8"	G	MXF	316 SS	0.25	22.0	22.0	62	54.0	3.2
WN1432P	1/4"	G	MxF	316 SS	0.25	22.0	22.0	62	54.0	3.2
WN1433P	3/8"	G	MXF	316 SS	0.25	28.5	28.5	85	76.2	3.2
WN1434P	1/2"	G	MxF	316 SS	0.25	28.5	28.5	85	76.2	3.2
WN1435P	1/2" x 1/4"	G	MXF	316 SS	0.25	28.5	28.5	85	76.2	3.2
WN1436P	3/4"	G	MXF	316 SS	0.70	35.0	35.0	89	76.2	6.0
WN1437P	3/4" x 1/2"	G	MxF	316 SS	0.40	30.0	30.0	78	76.2	4.2
WN1438P	1"	G	MXF	316 SS	0.70	45.0	45.0	112	90.0	6.0
WN1439P	1" x 1/2"	G	MXF	316 SS	-	45.0	45.0	112	90.0	9.0

WGI 2 Valve Hard Seat Threaded Manifold



Carbon Steel / Stainless Steel

For use with pressure transmitters, switches, gauges, etc. A block valve providing instrument isolation and a drain/vent allowing for venting, draining or calibration.

Specifications

Connection

Instrument and Process – 1/2" NPT (F)

Maximum Operating Pressure
6,000 PSI @ 200°F

Body & Bonnet Materials
ASTM - A - 105N / ASME - A - 479

Gland Packing

Adjustable, below stem thread design (PBT), prevent process fluid contact with stem threads. PTFE for temperature below 500°F/ Graphite for temperature above 500°F.

Stem

Close tolerance surface finish, cold rolled threads
ASME - SA - 479

Needle Tip

Self centering hardened and ground ASME SA-479 Type 316 SS

Temperature Rating

-40°F — 500°F (-40°C — 260°C)



Part Number	Material	
WM21514	CS NACE	NPT x NPT
WM21314	316 SS	NPT x NPT

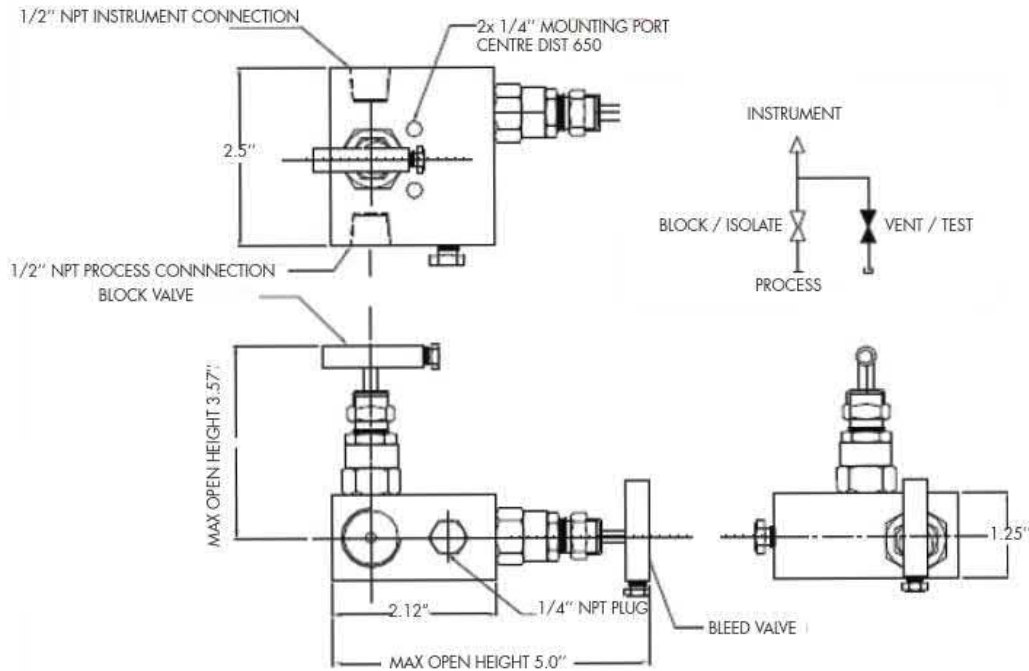

WGI 3 Valve Hard Seat Threaded Manifold



Carbon Steel / Stainless Steel

For use with differential pressure transmitters and multi-variable transmitters. Two block valves provide instrument isolation and one equalizing valve is positioned between the high and low transmitter process connections.

Specifications

Connection

Instrument and Process – 1/2" NPT (F)

Maximum Operating Pressure

6,000 PSI @ 200°F

Body & Bonnet Materials

ASTM - A - 105N / ASME - A - 479

Gland Packing

Adjustable, below stem thread design (PBT), prevent process fluid contact with stem threads. PTFE for temperature below 500°F/graphite for temperature above 500°F.

Stem

Close tolerance surface finish, cold rolled threads, ASME - SA - 479

Needle Tip

Self centering hardened and ground ASME SA-479 Type 316 SS

Temperature Rating

-40°F — 500°F (-40°C — 260°C)



Part Number	Material	
WM31514	CS NACE	NPT x NPT
WM31314	316 SS	NPT x NPT

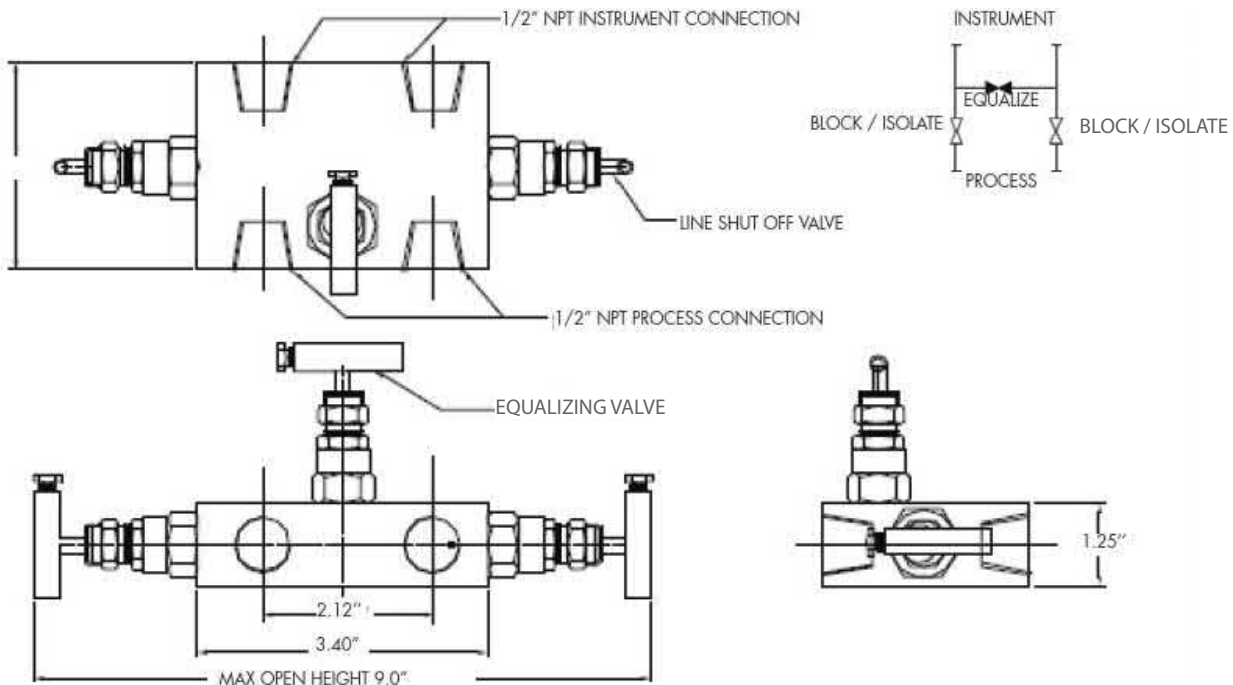

WGI 5 Valve Soft Seat Threaded Manifold



Carbon Steel / Stainless Steel

For use with differential pressure transmitters or chart recorders. The five manifolds include one remote mounted, two process isolation valves, two equalizing valves and one drain valve on a single block.

Specifications

Connection

Instrument and Process – 1/2" NPT (F) / NPT x Flanged

Maximum Operating Pressure

6,000 PSI @ 200°F

Body & Bonnet Materials

ASTM - A - 105N / ASME - A - 479

Gland Packing

Adjustable, below stem thread design (PBT), prevent process fluid contact with stem threads. PTFE for temperature below 400°F/Graphite for temperature above 400°F.

Stem

Close tolerance surface finish, cold rolled threads, ASME - SA - 479

Needle Tip

Self centering hardened and ground ASME SA-479 Type 316 SS

Seat Material

Delrin

Temperature Rating

-40°F — 200°F (-40°C — 93°C)



Part Number	Material	
WM55514	CS NACE	NPT x NPT
WM55314	316 SS	NPT x NPT
WM55514FN	CS NACE	NPT x Flanged
WM55314FN	316 SS	NPT x Flanged

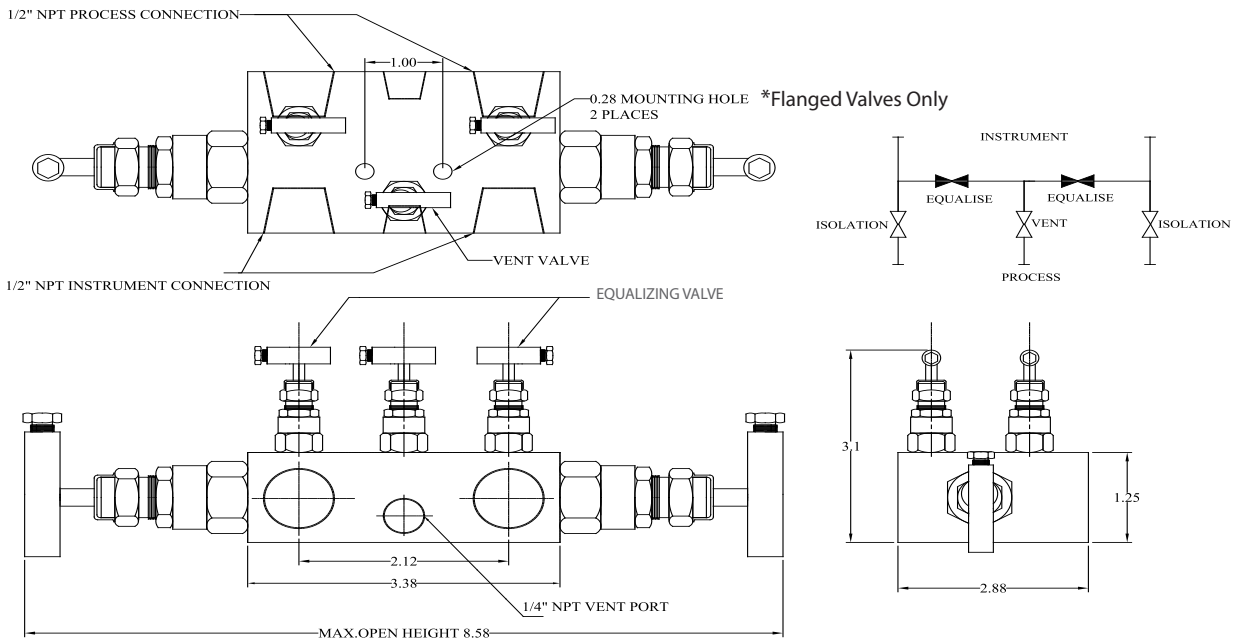

Norriseal-WellMark Regulators - Mega Gun II - W1301



Norriseal-WellMark's Mega Gun II is a direct-acting, self-operated, high pressure gas regulator. Effective reduction of high-pressure gas to operate controllers, valve actuators and chemical injection pumps as well as to supply fuel gas to pilot operated fire tubes on various production equipment.

Specifications

Maximum Inlet Pressure
6,000 PSI

Output Pressure Ranges
75, 150, 225 PSI

Flow Coefficient (CV)
0.13 Approximately

Port Size
1/4" NPT

Temperature Limits
-20°F — 180°F (-28°C — 82°C)

Body Materials
Brass or nickel

Vent
Four holes 5/32"

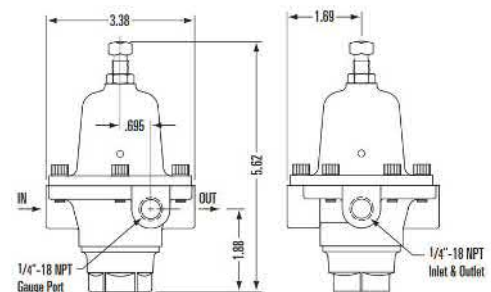

Norriseal-WellMark Regulators - Top Gun - 2001PR

Norriseal-WellMark's Top Gun regulator series is designed for accurate reduction of high pressure gas before it enters the distribution system.

Specifications

Maximum Inlet Pressure
1,500 PSI

Output Pressure Ranges
27 - 500 PSI

Seat Ring Orifices
1/8", 3/16", 1/4", 3/8", 1/2"

Connection
1" and 2" FNPT

Temperature Limits
-20°F — 150°F (-28°C — 65°C)

Body Material
Cast steel WCB

Optional
NACE compatible

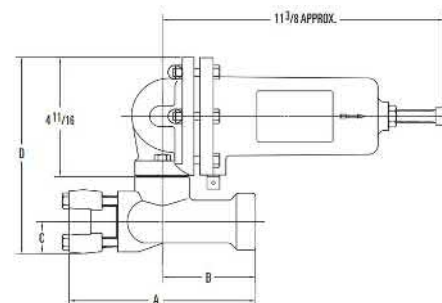

Norriseal-WellMark Regulators - Mighty Gun - 2002PR



This self-contained pressure-reducing regulator is designed for flexibility and is for low and high pressure systems. It can be used with natural gas, air or other gases.

Specifications

Maximum Inlet Pressure
10 — 2,000 PSI

Output Pressure Ranges
5 — 95 PSI

Seat Ring Orifice
 $\frac{3}{32}$ " $\frac{1}{8}$ " $\frac{3}{16}$ " $\frac{1}{4}$ " $\frac{3}{8}$ " $\frac{1}{2}$ "

Connection
1" and 2" FNPT

Temperature Limits
-20°F — 180°F (-28°C — 82°C)

Body Material
Cast steel WCB

Optional
NACE Compatible

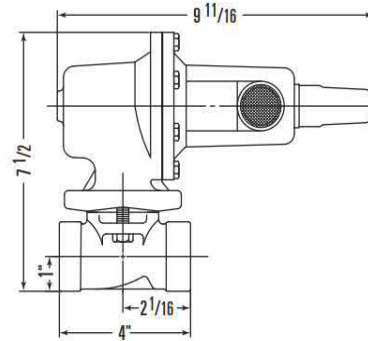
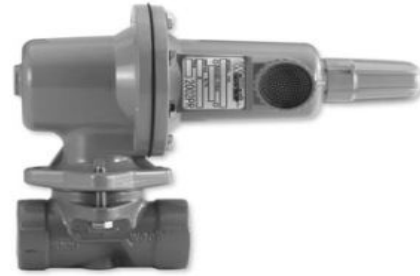

Norriseal-WellMark Regulators - Mini Gunn II - WG7

The Mini Gunn II series of regulators are standard equipment for pneumatic liquid level control and valve positioners and provide constant and reliable controlled reduced pressures.

Specifications

Maximum Inlet Pressure
250 PSI

Output Pressure Ranges
35, 60, 120, PSI

Body Material
Diecast aluminum

Port Size
 $\frac{1}{4}$ " FNPT

Temperature Limits
-20°F — 180°F (-28°C — 82°C)

Relieving
Standard self-relieving
NACE non-relieving

Optional
NACE Compatible



Filtered unit

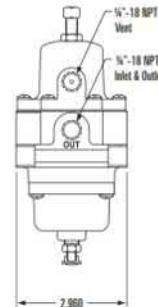
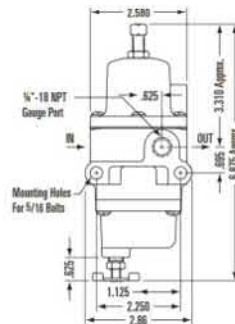

Non-filtered unit

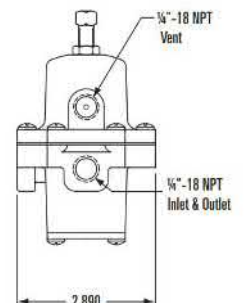
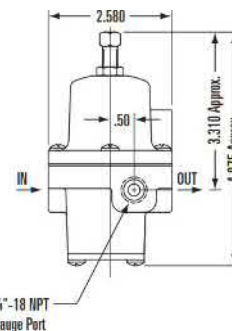









Norriseal-WellMark Level Controls







Norriseal-WellMark has been a leading supplier of valve and control solutions for more than six decades. Renowned for innovative designs and precision manufacturing, their products are used worldwide in a range of industries including oil and gas production and transmission, refining, petrochemical/chemical processing, marine, power generation, pulp and paper, food and beverage, high-pressure HVAC, steel manufacturing and other applications.



	Model Number	Description	Benefits
	Series 2001NB	No-Bleed, High-Pressure Level Control	Field Interchangeable, Cost Effective, Electric Option Available
	Series 9311	No-Bleed, High-Pressure Level Control	Field Interchangeable, Cost Effective, Electric Option Available
	Series 9321	External Cage Level Switch	Field Interchangeable, Cost Effective, Electric Option Available
	Series W1200DVO	High-Pressure, Pneumatic Level Switch	Field Interchangeable, Simple Design, Compact, Reliable
	Series 790	High-Pressure, Electric Level Switch	316 SS Cap, Body and Wetted Parts, Electrical Adapter Included
	Series 6900 Cantilever	High-Pressure, Torque-Tube Level Control	No-Bleed Version with Mizer Nozzle
	Series 7400 Snaptrol	No-Bleed, Low-Pressure Level Switch	Cost Effective, Reliable
	Series 1850 Float-Nose	Mechanical Lever Operated, Level Control	Cost Effective, Short Lead Times
	Series 685 Headswitch	Atmospheric Tank-Level Indicator	Many Options

Norriseal-WellMark has been a leading supplier of valve and control solutions for more than six decades. Renowned for innovative designs and precision manufacturing, their products are used worldwide in a range of industries including oil and gas production and transmission, refining, petrochemical/chemical processing, marine, power generation, pulp and paper, food and beverage, high-pressure HVAC, steel manufacturing and other applications.



	Model Number	Description	Benefits
	Series 1010	Burner Control Valve or Low Pressure Motor Valve	Cost Effective, Reliable, 300 PSI Working Pressure
	Series 3030	Low Pressure Motor Valve	Cost Effective, Reliable, High Cv Factors for Better Flow Rates
	Series 1250	Mechanical Lever Operated Dump Valve	Cost Effective, 500 PSI Working Pressure, Balance Double-Seat for High Flow
	Series WDV	High-Pressure Motor Valve	Field Interchangeable, Easy Maintenance, Cost Effective

Floating ball valves and trunnion mounted ball valves, are ideally used for shutoff applications.

Specifications

Product Range
Size NPS 2 — NPS 48
Class 150 — Class 2500

Design Features
Full or reduced bore
RF, RTJ, BW or PE
Side entry, top entry or welded body design
Double block and bleed, double isolation bleed
Emergency seat and stem injection
Anti-static device
Anti-blowout stem cryogenic or high temperature extended stem

Materials
Forged, casting, monel, inconel, hastelloy



Floating Ball Valve



Trunnion Ball Valve



FBV Gate Valves

Gate valves are often used when a straight in-line flow of minimum restriction is desired.

Specifications

Product Range
Size NPS 2 — NPS 48
Class 150 — Class 2500

Design Features
Full or reduced bore
RF, RTJ or BW
Outside screw and yoke, rising stem
Bolted bonnet or pressure seal bonnet
Flexible or solid wedge
Renewable seat rings

Materials
Forged, alloy 20, monel, inconel, hastelloy

Cast Steel Gate Valve



Forged Steel Gate Valve



FBV Globe Valves

Used for regulating flow in a pipeline.

Specifications

Product Range
 Size NPS 1/2 — NPS 424
 Class 150 — Class 2500

Design Features
 RF, RTJ, BW or SW
 Outside screw and yoke, rising stem
 Bolted bonnet or pressure seal bonnet

Materials
 Forged, alloy 20, monel, inconel, hastelloy



Cast Steel Globe Valve



Forged Steel Globe Valve



FBV Check Valves

Check valves can be used in a wide variety of applications, as fluid can only flow in one direction.

Specifications

Product Range
 Size NPS 1/2 — NPS 48
 Class 150 — Class 2500

Design Features
 Full or reduced bore
 RF, RTJ, BW, SW or NPT
 Bolted cover or pressure seal cover
 Dual plate or single plate
 Wafer, lug and flanged

Materials
 Forged, casting, alloy 20, monel, inconel, hastelloy



Cast Steel Swing Valve

Wafer Check Valve



Forged Steel Check Valve

FBV Plug Valves

Plug valves use a cylindrical or tapered plug with a hole in the center to control flow.

Specifications

Product Range
 Size NPS 1/2 — NPS 36
 Class 150 — Class 2500

Design Features
 Full or reduced bore
 RF, RTJ or BW
 Sleeve type or pressure seal balance

Materials
 Forging, casting, monel, inconel, hastelloy



Additional Product Lines (Distributed Products)



- ** Differential Pressure Gauges (DPI)
- ** Gauge Minders
- ** Backflow Test Kits



- ** Thermocouple
- ** RTD's
- ** Explosion Proof Heads
- ** Wire
- ** Accessories



- ** Magnehelic Gauges
- ** Flow Meters
- ** Level Gauges / Switches
- ** Pressure Switches
- ** Pressure Transducers



- ** High Pressure Valves
- ** High Pressure Fittings
- ** Pumps and Intensifiers
- ** Vessels



- ** Air / Gas Regulators
- ** Pressure Gauges
- ** I/P and E/P Transducers
- ** FRL's
- ** Diaphragm Cylinders



- ** High Pressure Ball Valves
- ** High Pressure Check Valves



- ** Direct Drive Pressure Gauges



- ** Calibration Fittings
- ** High Pressure Swivels
- ** TwistMate Connectors



- ** Digital Thermometers
- ** Pocket Thermometers
- ** Min/Max Thermometers
- ** Food Service Products



- ** The most reliable chemical injection pump
- ** Pumps available at any price
- ** Rental Options



- ** Flanged Safety Valves
- ** Threaded Safety Valves
- ** Clean Service Safety Valves
- ** Change Over Valves
- ** Pilot Operated Safety Valves



- ** Valves
- ** Regulators
- ** Pressure Controllers
- ** Liquid Level Gauges
- ** Accessories



- ** Ball Valves
- ** Gate Valves
- ** Globe Valves
- ** Check Valves
- ** Plug Valves



For more information on Western Gauge & Instruments contact your local Unified branch.

CALGARY 403.215.7800 | EDMONTON 780.469.0090 | BROOKS 403.362.4272 | RED DEER 403.340.3922
 GRANDE PRAIRIE 780.539.7800 | BONNYVILLE 780.826.2604 | FORT ST. JOHN 250.787.0080